

STATE OF HAWAII  
DEPARTMENT OF TRANSPORTATION  
AIRPORTS

SPECIFICATIONS AND PROPOSAL  
FOR  
REPLACE IIT CONFERENCE CENTER ROOM DIVIDERS  
DANIEL K. INOUE INTERNATIONAL AIRPORT  
HONOLULU, OAHU, HAWAII  
STATE PROJECT NO. CO1342-43

2023

**NOTICE TO BIDDERS**  
(Chapter 103D, HRS)

SEALED BIDS for REPLACE ROOM DIVIDERS AT IIT CONFERENCE CENTER, DANIEL K. INOUE INTERNATIONAL AIRPORT, HONOLULU, OAHU, HAWAII, STATE PROJECT NO. CO1342-43, will begin as advertised on May 17, 2023, in HiePRO. Bidders are to register and submit bids through HiePRO only. See the following HiePRO link for important information on registering: <https://hiepro.ehawaii.gov/welcome.html>.

Deadline to submit bids is June 15, 2023, 2:00 P.M., Hawaii Standard Time (HST). The complete bid Proposal Schedule shall be uploaded into HiePRO prior to bid opening date and time. All other required confidential and proprietary documents shall be uploaded separately. Failure to upload the bid Proposal Schedule into HiePRO shall be grounds for rejection of the bid. Bids received after said due date and time shall not be considered.

The scope of work consists of removing and replacing the existing room dividers at the Interisland Terminal (IIT) Conference Center with new operable partitions according to the specifications. The estimated construction cost is between \$300,000 and \$350,000.

To be eligible for award, bidders must possess a valid State of Hawaii Specialty Contractor's "C-25" License at the time of bidding.

The GENERAL PROVISIONS dated 2016 applicable to this project are available on the internet at <http://hidot.hawaii.gov/administration/con/>.

ALL requests for information shall be received in writing via HiePRO prior to the Question Due Date in the General Information of the HiePRO solicitation. Questions received after the deadline will not be addressed. Verbal requests for information will not receive a response.

Apprenticeship Preference. A 5% bid adjustment for bidders that are parties to apprenticeship agreements pursuant to §103-55.6, HRS, is applicable to this project.

Employment of State Residents on Construction Procurement Contracts. Compliance with §103B-3, HRS is a requirement for this project whereby a minimum of 80% of the bidder's work force on this project must consist of Hawaii residents.

Campaign contributions by State and County Contractors. Contractors are hereby notified of the applicability of §11-355, HRS, which states that campaign contributions are prohibited from specified State or county government contractors during the term of the contract if the contractors are paid with funds appropriated by a legislative body. For more information, contact the Campaign Spending Commission at (808) 586-0285.

Protests. Any protest of this solicitation shall be submitted in writing to the Director of Transportation, in accordance with §103D-701, HRS and §3-126, HAR.

The Equal Employment Opportunity Regulations of the Secretary of Labor implementing Executive Order 11246, as amended, shall be complied with on this project.

The U.S. Department of Transportation Regulation entitled "Nondiscrimination in Federally-Assisted Programs of the U.S. Department of Transportation," Title 49, Code of Federal Regulations (CFR), Part 21 is applicable to this project. Bidders are hereby notified that the Department of Transportation will affirmatively ensure that the contract entered into pursuant to this advertisement will be awarded to the lowest responsible bidder without discrimination on the grounds of race, color, national origin, or sex (as directed by 23 CFR Part 200).

For additional information, contact Mr. Benton Ho, our Airports State Project Manager, at (808) 838-8804 or by email at benton.ho@hawaii.gov.

The State reserves the right to reject any or all proposals and to waive any defects in said proposals for the best interest of the public.



---

EDWIN H. SNIFFEN  
Director of Transportation

Posted:

## TABLE OF CONTENTS

	<u>Page</u>
Notice to Bidders .....	NTB 1 to NTB 2
Instructions for Contractor's Licensing .....	HAI
Special Provisions .....	SP-1 to SP-8
Wage Rate Schedule (Not Physically included in the Bid Documents)	

### SPECIFICATIONS

#### PART I - GENERAL PROVISIONS

General Provisions for Construction Projects, 2016 (Not physically included)

#### PART II – TECHNICAL PROVISIONS

##### DIVISION 1 - GENERAL REQUIREMENTS

SECTION 01010 DESCRIPTION OF WORK.....	01010-1 to 01010-8
SECTION 01300 SUBMITTALS .....	01300-1 to 01300-9
SECTION 01400 CONTRACTOR QUALITY CONTROL PROGRAM.....	01400-1 to 01400-9
SECTION 01524 CONSTRUCTION WASTE MANAGEMENT .....	01524-1 to 01524-8
APPENDIX A .....	Tables 1, 2, and 3
SECTION 01560 ENVIRONMENTAL CONTROLS .....	01560-1 to 01560-6
SECTION 01561 CONSTRUCTION SITE RUNOFF CONTROL PROGRAM.....	01561-1 to 01561-22
SECTION 01562 MANAGEMENT OF CONTAMINATED MEDIAS .....	01562-1 to 01562-17
SECTION 01565 SECURITY MEASURES .....	01565-1 to 01565-3
SECTION 01580 TEMPORARY FACILITIES AND UTILITIES.....	01580-1 to 01580-2
SECTION 01700 MOBILIZATION, DEMOBILIZATION .....	01700-1 to 01700-2

##### DIVISION 10 - SPECIALTIES

SECTION 10222 OPERABLE PARTITIONS.....	10222-1 to 10222-5
--	--------------------

Requirements of Chapter 104, HRS (eH104-3, Rev 04/21) ..... 1 to 2

Proposal.....P-1 to P-6

Proposal Schedule .....P-7 to P-8

Surety Bid Bond (r11/17/98)

FORMS

Performance Bond (Surety)

Performance Bond

Labor and Material Payment Bond (Surety)

Labor and Material Payment Bond

Chapter 104, HRS Compliance Certification

Certification of Compliance for State Resident (ACT 192, SLH 2011)  
Provisions to be Included in Construction Procurement Solicitation

## **INSTRUCTIONS FOR CONTRACTOR'S LICENSING**

"A" general engineering contractors and "B" general building contractors are reminded that due to the Hawaii Supreme Court's January 28, 2002 decision in Okada Trucking Co., Ltd. v. Board of Water Supply, et al., 97 Haw. 450 (2002), they are prohibited from undertaking any work, solely or as part of a larger project, which would require the general contractor to act as a specialty contractor in any area where the general contractor has no license. Although the "A" and "B" contractor may still bid on and act as the "prime" contractor on an "A" or "B" project (*See, HRS § 444-7 for the definitions of an "A" and "B" project.*), respectively, the "A" and "B" contractor may only perform work in the areas in which they have the appropriate contractor's license (*An "A" or "B" contractor obtains "C" specialty contractor's licenses either on its own, or automatically under HAR § 16-77-32.*). The remaining work must be performed by appropriately licensed entities. It is the sole responsibility of the contractor to review the requirements of this project and determine the appropriate licenses that are required to complete the project.

STATE OF HAWAII  
DEPARTMENT OF TRANSPORTATION  
AIRPORTS

SPECIAL PROVISIONS

## SPECIAL PROVISIONS

The following additional amendments to the General Provisions are applicable to this project:

### 1.3 DEFINITIONS is amended as follows:

The following definition shall be deleted in its entirety and replaced with the following:

“Subcontractor - An individual, partnership, firm, corporation, or joint venture, or other legal entity, as licensed or required to be licensed under Chapter 444, Hawaii Revised Statutes, as amended, which enters into an agreement with the Contractor to perform a portion of the work.”

Add the following to 1.3 Definitions:

“HAWAII ePROCUREMENT SYSTEM (HIePRO) - The State of Hawaii eProcurement System for issuing solicitations, receiving proposals and responses, and issuing notices of award.”

### 2.7 REQUEST FOR SUBSTITUTION OF SPECIFIED MATERIALS AND EQUIPMENT BEFORE BIG OPENING is amended as follows:

The last sentence in the first paragraph (line 147 to 152) shall be replaced with the following:

“Where a bidder intends to use a material or equipment of an unspecified brand, make, or model, the bidder must submit a request to the Department for review and approval at the earliest date possible. Requests shall be submitted via email to the Contact person listed in HIePRO for the solicitation and also posted as a question in HIePRO under the question/answer tab referencing the email with the request. The request must be posted in HIePRO no later than seventeen (17) calendar days before the bid opening date, not including the bid opening date.”

The first sentence in the second paragraph (line 154 to 156) shall be replaced with the following:

“It shall be the responsibility of the bidder to submit sufficient evidence based upon which a determination can be made by the Department that the alternate brand is a qualified equivalent.”

### 2.8 PREPARATION AND DELIVERY OF BID is amended as follows:

Last Paragraph (line 189 to 192) shall be replaced with the following:

“The bidder shall submit the proposal in HIePRO. The

proposal shall be UPLOADED to HIePRO prior to the bid opening date and time. Proposals received after said due date and time shall not be considered. Original (wet ink) proposal documents are not required to be submitted. The award will be made based on proposals uploaded in HIePRO. Any and all other additional documents explicitly designated and labeled as CONFIDENTIAL OR PROPRIETARY shall be UPLOADED SEPARATELY to HIePRO. If there is a conflict between this specification and its HIePRO solicitation, the specifications shall govern and control unless otherwise specified."

2.11 BID SECURITY is amended as follows:

Delete (a) in its entirety and replace with the following:

"(a) Unless directed otherwise in the invitation for bids, each bid shall be accompanied by bid security which is intended to protect the Department against the failure or refusal of a bidder to execute the contract for the work bid or to supply the required performance and payment bonds. Bid security shall be in an amount equal to at least five percent of the base bid and additive alternates. Bid security shall be in one of the following forms:

- (1) A deposit of legal tender;
- (2) A valid surety bid bond, underwritten by a company licensed to issue bonds in the State of Hawaii; or
- (3) A certificate of deposit; credit union share certificate; or cashier's, treasurer's, teller's, or official check drawn by or a certified check accepted by a bank, savings institution, or credit union insured by the Federal Deposit Insurance Corporation (FDIC) or the National Credit Union Administration (NCUA) and payable at sight or unconditionally assigned to the Department. These instruments may be utilized only to a maximum of one hundred thousand dollars (\$100,000.00). If the required amount totals over one hundred thousand dollars (\$100,000.00), more than one instrument not exceeding one hundred thousand dollars (\$100,000.00) each and issued by different financial institutions shall be accepted.

If bidder elects options (1) or (3) above for its bid security, said bid security shall be in its original form and shall be submitted before the bid deadline to the Contract Office, Department of Transportation, AliiAIMOKU Hale, 869 Punchbowl Street, Room 105, Honolulu, Hawaii 96813. Original surety bid bonds do not need to be submitted to the Contracts Office. Bidders are reminded that a copy of this bid bond shall be included with its bid uploaded to HIePRO."

2.12 PRE-OPENING MODIFICATION OR WITHDRAWAL OF BIDS is amended as follows:

Delete 2.12 PRE-OPENING MODIFICATION OR WITHDRAWAL OF BIDS in its entirety and replace with the following:

"2.12 PRE-OPENING MODIFICATION OF WITHDRAWAL OF BIDS. A bidder may withdraw or modify a proposal after the bidder submits the proposal in HIEPRO. Withdrawal or modification of proposal must be completed before the time set for the receiving of bids."

2.14 PUBLIC OPENING OF BIDS is amended by deleting 2.14 PUBLIC OPENING OF BIDS in its entirety.

4.12 UTILITIES AND SERVICES is amended as follows:

Add the following after the last paragraph:

"(e) Repairs and Outages.

- (1) The Contractor shall have available on 24-hour call sufficient specialty contractors, such as electrical and plumbing contractors, to repair any damage to existing facilities that might occur as a result of construction operations regardless of when the damage might occur.
- (2) Outage: Written requests for power outage, communication changes, and water and sewer connection outages shall be submitted to the Engineer at least seven (7) days in advance or as specified in other sections of these specifications. Outages will be restricted to non-peak operational hours between midnight and 6:00 a.m."

7.21 PUBLIC CONVENIENCE AND SAFETY - is hereby added to the General Provisions:

"It shall be especially noted by the Contractor that the area directly adjacent to the existing in use runways and taxiways, is an extremely hazardous area and that very strict controls will apply throughout the entire period required to complete all work within 500 feet from the edge of an in use runway and 180 feet from the edge of an in use taxiway.

The Contractor shall familiarize himself with the Airport Certification Manual available for review at the Airport Manager's Office and shall comply with its requirements.

The Contractor is responsible for the security of access points to the Airport Operational Area that are located within the limits of construction and will be fined \$1,000 per incident for any breach of security at these locations.

All gates leading into the AOA shall be kept locked and if required to be open, the Contractor shall provide professional

security guards to attend gates. The guards must be approved by the Director and shall be required to attend a training session conducted by the Airport Manager prior to gate assignment."

8.20 OPERATION OF CONTRACTOR'S MOTOR VEHICLE AND PERSONNEL IN RESTRICTED AIR OPERATIONS AND MOVEMENT AREAS is hereby added to the General Provisions:

"The Contractor shall conform with the all sections of the "State of Hawaii, Department of Transportation, Airports Division, Contractor's Training Guide" pertaining to access and operation in the Airport Operation Area (AOA) hereinafter described as follows:

"A. Motor Vehicles in Airport Operation Area

For safety reasons, the operation of motor vehicles in the AOA must conform with all applicable State Airport rules and regulations."

B. Motor Vehicle Access Permit

Each motor vehicle operated in the AOA is required to:

1. Meet all State licensing registration and safety requirements and be specifically licensed for operation in the AOA.
2. Meet all insurance requirements.
3. Be restricted to operation by those persons qualified to drive the vehicle and in possession of a current Ramp Driver's License and applicable Motor Vehicle Operator's License.

C. The operators of motor vehicles in the AOA shall be responsible for meeting the following insurance requirements.

1. Licensed Vehicles

As a condition for authorization to enter the AOA, the Contractor shall provide evidence of vehicle liability insurance in the form of a Certificate of Insurance issued by an authorized insurance carrier. Automobile Liability and general Liability (combined single limit, Bodily Injury and Property Damage, per occurrence) shall be required in the applicable minimum limits specified below:

a. Daniel K. Inouye International Airport

(1) Standard AOA clearance. . . \$5,000,000

(2) Limited AOA clearance. . . . \$1,000,000

Limited AOA clearance is defined as operations restricted to Diamond head and Ewa Concourses second level roadways and connecting third level main terminal roadway only, with entry and exit via Security Access Point "C" (Primary) and Access Point "A" (Secondary)

b. Other Airports

Standard AOA clearance. . . . . \$1,000,000

Standard AOA clearance is defined as any portion of a public Airport from which the public is restricted by fences or appropriate signs and not leased or demised to anyone for exclusive use and shall include runways, taxiways, all ramp and apron areas, aircraft parking and storage areas, fuel storage areas, maintenance areas, and any other area of a public Airport used or intended to be used for landing, takeoff, or surface maneuvering of aircraft or used for embarkation or debarkation of passengers.

2. Unlicensed Vehicles

Airport Liability (or General Liability) shall be required in the applicable minimum limits specified below:

a. Daniel K. Inouye International Airport, Kahului Airport and Ellison Onizuka Kona International Airport at Keahole

AOA clearance. . . . . \$5,000,000

b. All other Airports

AOA clearance. . . . . \$1,000,000

3. Specifically name the State of Hawaii as additionally insured.

4. Indicate that the Airport Engineer will be provided with a 30-day written prior notice of policy cancellation or material change in coverage or conditions.

D. Operator's Permit

1. No person shall operate a motor vehicle on the AOA unless he holds and carries on his person a current Airport Motor Vehicle operator's permit issued by the State of Hawaii, Department of Transportation, Airports Division.
2. Operator's permits will only be issued to persons who apply through the Airport District Security Office and pass a written exam covering those portions of the Airport Rules and Regulation relating to the operation of vehicles in Airport Operations Areas.

E. Authorized Vehicles

1. Only vehicles considered operationally safe and necessary for the performance of this contract may be allowed to operate in the AOA.
2. All motor vehicles must be painted in such a manner so as to be easily identifiable and must carry the Contractor's name on each side. These signs may be of a temporary nature applied to the side windows or doors.

The lettering shall be in bold characters of a minimum of four (4) inches in height and one and one-half (1-1/2) inches in widths, the height of logos should be a minimum of six (6) inches.

3. The Contractor's operations on, over, across, and/or immediately adjacent to any runway and/or taxiway at a towered airport shall require the use of two-way radio communication. The Contractor shall obtain the necessary equipment at his own expense.
4. No person shall operate a motor vehicle on the AOA unless he holds and carries on his person a current Motor Vehicle Operator's Permit issued by the Airport Manager.
  - a. The Motor Vehicle Operator's Permit will be issued only to persons who apply through the Airport Security Section and pass a written exam covering those portions of the Airport Rules and Regulations relating to the operation of vehicles in the AOA.
  - b. Permits issued may be suspended or revoked for cause at any time by the Airports Division.

F. Airport Operation Area Construction Pass

1. Issuance of Airport Operation Area (AOA) Construction Passes shall be limited to contractors, subcontractors, companies, organizations, individuals engaged in authorized and approved construction activity which requires a continuing need for entry into the AOA or Airfield Movement Areas. Request letters for such passes must be made to the Airport District Manager's Office in accordance with the Contractors Training Guide or applicable District requirements.
2. As a condition for security area clearance, applicants must comply with Transportation Security Regulation 1542 which requires a ten-year background Criminal History Records Check for those individuals employed under this contract.

G. Gate Guards Furnished by Contractors

1. If a contractor is permitted by the airport to maintain operational control of an AOA Access Gate, entry through such gate shall be controlled by the posting of a gate guard.
  - a. Written instruction will be provided, outlining the guard's duties to enforce those requirements and provisions prescribed by the airport's security program to include all personnel and vehicle entry and access requirements.
  - b. Procedures will be established to identify the actions which will be undertaken by the guard in calling for assistance.
  - c. An approved emergency communications procedure will be established.

H. Compliance

1. The contractor shall comply with all regulations and rules governing the Air Operations Areas during construction, as specified in the following or later versions:
  - a. Hawaii Revised Statutes, Title 19, Administrative Rules for Public Airports.
  - b. Federal Aviation Administration Advisory Circular AC 150/5340-1M, Standards for Airport Markings; AC 150/5370-2G, Operational Safety on Airports During Constructions.

I. Enforcement Authorization

Act 21, Section 1, Section 261-17(a), HRS; Federal Aviation Administration Regulations, Part 139, Part 107.

J. Right of Rejection or Revocation

The State of Hawaii, Department of Transportation, Airports, reserves the right to withhold, deny or revoke any airport security clearance, licenses or permits to any individual or organization who fails to meet the prescribed or required access area clearance criteria to include background investigation information, or fails to observe or comply with established rules, regulations, and directives.

It should be clearly understood that such denial or revocation is based solely on airport security or safety considerations and does not in any way constitute a determination by the State with regard to private employment by any individual or organization."

- END OF SECTION -

STATE OF HAWAII  
DEPARTMENT OF TRANSPORTATION  
AIRPORTS

SPECIFICATIONS

STATE OF HAWAII  
DEPARTMENT OF TRANSPORTATION  
HONOLULU, HAWAII

**SPECIFICATIONS**

**PART I**

**GENERAL PROVISIONS**

The Hawaii Department of Transportation AIR and WATER Transportation Facilities Division General Provisions for Construction Projects dated 2016 is not physically included in these specifications. The General Provisions are available at

<http://hidot.hawaii.gov/administration/con/>

STATE OF HAWAII  
DEPARTMENT OF TRANSPORTATION  
HONOLULU, HAWAII

**SPECIFICATIONS**

**PART II**

**TECHNICAL PROVISIONS**

DIVISION 1 – GENERAL REQUIREMENTS

SECTION 01010 - DESCRIPTION OF WORK

PART 1 - GENERAL

1.01 RELATED DOCUMENTS

The General Provisions for Construction Projects (2016), Special Provisions and General Requirements of the Specifications, apply to the work specified this Section.

1.02 SCOPE OF WORK

A. The work involves the replacing of the room dividers at the Interisland Terminal (IIT) Conference Center at Daniel K. Inouye International Airport (HNL). Work to include but not limited to the following:

1. Removal and disposal of the existing room partitions.
2. Examination and preparation of the supports and substrates prior to installation. Prepare and clean substrate surfaces according to methods recommended by the manufacturer.
3. Deliver materials to the HNL Airport by clearly marking packages with the numbering systems used on the Shop Drawings. Don't use permanent markings on panels.
4. Protect the panels during delivery, storage, and handling to comply with the manufacturer's instructions as required to prevent any damage occurring.
5. Provide operable partition manufacturer's written warranty agreeing to repair or replace components with manufacturing defects for a period of two years minimum.

B. The work to be performed under this Contract shall also include preparing and obtaining all permits required to complete this project and other related works as called for on the plans and these specifications.

1.03 PERMITS

A. The Contractor is responsible for any permits, if required, before starting the construction. Department of Transportation, Airports (DOTA) anticipates that the following permits will be required for this project:

- 1) None anticipated at this time.

B. The Contractor is responsible for the preparation and submittal of application

document(s) to the appropriate permitting agency, payment of application fee(s), and all other work necessary to obtain all required permit(s) prior to starting construction operations at the project site. Construction operations shall not start until all required permits are approved by the appropriate permitting agencies and copies submitted to the Engineer for the record.

- C. Bidders are responsible for researching and confirming which permits are and are not necessary for this project. Bidders shall exercise due diligence in researching what permits, if any, are required beyond those mentioned in Part 1.03(A) above. If a permit beyond those mentioned in Part 1.03(A) above is found to be necessary for this project, then bidders shall factor the additional cost of obtaining this permit into their bid. Permits that are found to be required after bid opening shall be obtained at no additional cost to the State.
- D. All fines levied against this project as a result of failing to apply for a required permit prior to starting work shall be borne entirely by the Contractor.
- E. All work necessary for researching permits, determining their necessity for this project, preparation and submittal of permit application document(s), payment of application fee(s), etc. up to the issuance of the approved permit(s) are considered incidental to the Contract.

#### 1.04 ALLOWANCE

- A. Allowance includes, but not limited to, works required for environmental measures, when required by the regulation(s); unforeseen conditions and other measures, such as temporary safety measures, security measures, and material short supply when approved by the Engineer.
- B. Use the allowance only as directed by the Engineer for the airport's purposes and only by Change Orders that indicate amounts to be charged to the allowance.
- C. Contractor's overhead, profit, and related costs for products and equipment ordered by the Airport under the contingency allowance are included in the allowance and are not part of the Contract Sum. These costs include delivery, installation, taxes, insurance, equipment rental, and similar costs.
- D. Change Orders authorizing use of funds from the contingency allowance will include Contractor's related costs and reasonable overhead and profit margins.
- E. At project closeout, any unused amounts remaining in the Allowance will be credited back to the State.

#### HOURS OF WORK FOR CONSTRUCTION

- A. Work hours for construction are subject to the following:
  - 1. Work shall be performed between 8:00 p.m. to 5:00 a.m. Sunday night to

Monday morning. Bidders shall not assume that they will be given work windows during these hours. The Airport reserves the right to adjust work hours in order to provide minimum interruption to Airport Operations with no additional cost to the State.

2. Work hours shall be coordinated with the Airport Manager to provide minimum interruption to facility operations while performing work.
  3. The Contractor will be required to shift to night work hours, at no additional cost to the State. However, starting and ending times as well as duration may be adjusted by the Airport Manager depending on the actual flight schedules and airport operational considerations. Contractor vehicles and equipment are not allowed on the aircraft apron fronting the terminal from midnight to 6:00 a.m..
  4. Work hours shall be coordinated with the Airport Manager in order to protect the general public and airport employees from excessive dust and noise levels unless protective measures are taken by the Contractor (e.g. noise and/or dust control) to reduce the impact to a level acceptable to the Airport Manager.
- B. The Contractor shall work continuously throughout the project duration. The Contractor shall apply and receive approval from the Engineer in writing of all work occurring outside of normal work hours. The Contractor shall coordinate their schedule with the Engineer if rescheduling of work or intermittent work is required, such work shall be performed at no extra cost to the State. If the Contractor elects to work overtime, compensation for State employees and for State representatives, as authorized by the State, shall be in accordance with Article VII, Section 7.5 of the General Provisions.

#### 1.05 SITE VISIT

- A. The Contractor shall visit the work site and verify all conditions pertinent to the Contract he/she is bidding on.

#### 1.06 COORDINATION

- A. The Contractor shall coordinate the work of different trades and shall be solely responsible for fulfillment of requirements specified herein.

#### 1.07 SAFETY

- A. The Contractor shall take all necessary precautions to protect all his and/or her workmen and all other personnel from injuries. The rules and regulations promulgated by the Occupational Safety and Health Acts are applicable and made a part of these specifications.
- B. During the progress of the work, all debris, empty crates, waste, material drippings, etc., shall be removed by the Contractor at the end of each workday,

and the work area shall be left clean and orderly.

- C. Outage: Written requests for power outage shall be submitted to the Engineer at least seven (7) days in advance or as specified in other sections of these specifications. Outage will be restricted to non-peak operational hours.
- D. Barricades and warning signs shall be erected by the Contractor in the work area to properly protect all personnel in the area.

#### 1.08 VEHICLE PARKING

Public Parking is available first come first serve for a fee at all three Airport Parking Structures. Hourly and daily fee schedule is posted online at the Daniel K. Inouye International Airport website. <https://airports.hawaii.gov/hnl/getting-to-from/parking/>

Upon approval by the DOT-A, monthly passes at the International Parking Structure may be purchased at the rate of \$175/month, valid until the expiration date of the Contract. All costs associated with obtaining parking shall be incidental to the Contract. The Contractor shall submit the following information in writing to the State Project Manager, for consideration of approval for a monthly pass.

1. Business Name of Contractor
2. Project Number
3. Contract Number
4. Contract Expiration Date
5. Employee's Name/Job Title/Airport ID Media Badge Number
6. Effective Date Parking Requested for

#### 1.09 PROVISIONS FOR FIELD OFFICE/STORAGE SPACE

Bidders shall not assume that a field office and or storage space will be available on the Airport Property by the Notice to Proceed date. Pending the availability, the State may issue revocable permit(s) to the Contractor for the use of a space within the Airport Property, for \$25 each location/permit, to be used specifically for a field office and/or storage of materials and equipment. The State will make every effort to provide the Contractor with space on airport property, however, should the State determine that no space is available for such use(s), the responsibility shall then be on the Contractor to find space outside of airport property at no additional cost to the State.

#### 1.11 PROTECTION OF EXISTING STRUCTURES AND IMPROVEMENTS

- A. The Contractor shall preserve and protect all structures, equipment, and vegetations on/or adjacent to the work site, which are not to be removed and which do not unreasonably interfere with the work required under this Contract. The Contractor shall only remove trees when specifically authorized to do so and shall avoid damaging vegetation that will remain in place. If any limb or branches of trees are broken during Contract performance, or by the careless operation of equipment, or by workmen, the Contractor shall trim those limbs or branches with a clean cut and paint the cut with a tree-pruning compound as directed by the Engineer.
- B. The Contractor shall protect from damage all existing improvements and utilities at/or near the work site.

1.12 TEMPORARY CONSTRUCTION SIGNS

- A. The Contractor shall install temporary construction signs where the presence of planned construction areas will obstruct the existing signage or cause the closing of an existing method of egress or ingress and/or as directed by the State. Such signs shall be in accordance with the Department of Transportation – Airports Signage and Graphics Manual, highway standards for construction warning signs for background and text colors (white letters on fluorescent yellow background). Signs may be mounted on suitable approved material other than aluminum panels. The Contractor will be responsible to fabricate and install such signs. Costs related to this activity will be considered as incidental to and included in the bid price for the various items of work in this project.

1.13 OPERATION OF AIRPORT FACILITIES DURING CONSTRUCTION

- A. The Contractor shall coordinate the phases of work under this contract with the Engineer to permit the continuing operation of existing Airport facilities and to minimize disruption to pedestrian and vehicular traffic.
- B. Utility Maintenance: During the construction of this contract, existing utility services serving occupied or used facilities shall not be disrupted except where authorized in writing by authorities having jurisdiction. Contractor shall provide temporary services during interruptions to existing utilities, as acceptable to the Engineer. Damages to the existing utility facilities by the Contractor will be repaired at the Contractors expense.
- C. Outages for power, communications or any other utility, if necessary, shall be kept to a minimum and scheduled for off-peak hours, generally from 12:00 a.m. to 6:00 a.m.. The Contractor shall submit written requests to the Engineer for such outages no later than fourteen (14) calendar days in advance. The request shall include a description of work and the duration of the outage. The Contractor shall not proceed with such outages until written approval is received from the State.

1.14 CONSTRUCTION STAKES, LINES AND GRADES

- A. The Contractor shall perform all construction layout and reference staking

necessary for the proper control and satisfactory completion of all structures, grading, paving, drainage, sewer, water, and all other appurtenances required for the completion of the work.

- B. All construction staking shall be performed by qualified personnel under the direct supervision of a person with an engineering background who is experienced in the direction of such work and is acceptable to the Engineer.
- C. The Department may check the Contractor's control of the work at any times as the work progresses. The Contractor will be informed of the results of these checks, but the Department by doing so will in no way relieve the Contractor of his responsibility for the accuracy of the layout work. The Contractor shall at his expense correct or replace any deficient or inaccurate layout and construction work. If, as a result of these deficiencies or inaccuracies, the Department is required to make further studies, redesign, or both, all expenses incurred by the Department due to such deficiencies or inaccuracies, will be deducted from any payments due the Contractor.
- D. The Contractor shall furnish all necessary personnel, engineering equipment and supplies, materials, and transportation incidental to the accurate and satisfactory completion of this work.
- E. Unless otherwise provided, all requirements imposed by this section and performed by the Contractor shall be considered incidental to the various contract items and not separate or additional payment will be made thereof.

#### 1.15 OPERATIONS AND STORAGE AREAS

- A. Storage and staging areas may be available on a limited basis. Due to the number of projects in progress or projected to be in progress, the State does not guarantee the availability of such areas on airport property. The Contractor may request storage & staging area(s) within AOA fence once the Notice to Proceed date is set.
- B. The Contractor shall confine all operations (including storage of material) on the Airport premises to areas authorized or approved by the Engineer. The Contractor shall hold and save the DOTA free and harmless from liability of any nature occasioned by the Contractor's performance.
- C. The Contractor shall use only established roadways. When materials are transported in prosecuting the work, vehicle shall not be loaded beyond the loading capacity recommended by the manufacturer of the vehicle or prescribed by any Federal, State, or local laws or regulations. When it is necessary to cross curbs or sidewalks, the Contractor shall protect them from damage. The Contractor shall repair or pay for the repair of any damaged curbs, sidewalks, and roadways.

#### 1.16 CLEANING UP

- A. The Contractor shall at all times keep the work area, including storage areas, free from accumulations of waste materials. Before completing the work, the Contractor shall remove from the work and premises any rubbish, tools, scaffolding, equipment, and materials that are not the property of the DOTA. Upon completing the work, the Contractor shall leave the work area in clean, neat, and orderly condition satisfactory to the Engineer.

1.17 VERIFICATION OF DIMENSIONS

- A. The Contractor shall be responsible for the coordination and proper relation of his work to the work of all trades. The Contractor shall visit the premises and thoroughly familiarize himself with all details of the work and working conditions, to verify all dimensions in the field, and to advise the Owner's Representative of any discrepancy between the field measurements and the plan dimensions before performing any work.

1.18 STANDARDS & CODES

- A. Wherever references are made in the contract to the respective standards, specifications and advisory circulars in accordance with which work is to be performed or tested, it is to be understood that the edition or revision of the standards, specifications and advisory circulars in effect on the date of the bidder's proposal shall apply unless otherwise expressly set forth in the contract. Unless otherwise specified, reference to such standards is solely for technical information.
- B. In case of conflict among any such referenced standards and codes or between any such standard(s) or code(s) and the requirements of the Contract, the stricter requirement shall govern.

PART 2 – PRODUCTS (Not Used)

PART 3 – EXECUTION (Not Used)

PART 4 - MEASUREMENT AND PAVEMENT

4.01 BASIS OF MEASUREMENT AND PAYMENT

- A. Work under this section will not be measured nor paid for separately but shall be considered incidental to and included in the bid prices for the various items of work in this project.
- B. Work under this Section for unforeseen conditions shall be paid under allowance items in the Proposal Schedule. The allowance is an estimate and the amount shall not exceed the maximum amount shown in the Proposal Schedule.

<u>Item No.</u>	<u>Description</u>	<u>Unit Price</u>
01010.1	Unforeseen Conditions	Allowance

END OF SECTION

## SECTION 01300 - SUBMITTALS

### PART 1 - GENERAL

#### 1.01 RELATED DOCUMENTS

The General Provisions for Construction Projects (2016), Special Provisions and General Requirements of the Specifications, apply to the work specified in this section.

#### 1.02 PROJECT DOCUMENTATION

The contract will not be considered complete until required submittals have been received and accepted by the State.

At the discretion of the Project Manager, the number of copies to be submitted may differ from that specified in this Section.

#### 1.03 DETAILED CONSTRUCTION SCHEDULE

A. The Contractor shall submit a detailed construction schedule to the Engineer for review, no later than 30 calendar days after award of the contract. The detailed construction schedule shall be based on a detailed critical path analysis of construction activities and sequence of operations needed for the orderly performance and completion of any separable parts of any work and all work in accordance with the contract. The schedule shall be Critical Path Method (CPM) type in the form of an arrow diagram and activity listing or comprehensive bar graph. The network diagram shall show in detail and in orderly sequence all activities on a time scale, their descriptions, durations and dependencies, necessary and required to complete all work and any separable parts thereof. The schedule shall show in detail the following information for each activity:

1. Identification by code numbers and description;
2. Duration;
3. Craft and Equipment;
4. Earliest start and finish dates;
5. Latest start and finish dates;
6. Total and free float time; and
7. Highlighted Critical Path

B. The construction schedule shall be complete in all respects, covering in addition to activities at the site of work, off-site activities such as design,

fabrication, and procurement of equipment; the scheduled delivery dates of such equipment; submittal and approval of shop drawings and samples; ordering and delivery of materials; inspections; and testing. The schedule shall also include a manpower forecast by crafts. The detailed construction schedule shall be supplemented by a three-week schedule prepared by the Contractor and submitted to the Engineer on a weekly basis. The Contractor shall promptly inform the Engineer of any proposed change in the schedule and shall furnish the Engineer with a revised schedule and cash flow diagram within 15 calendar days after approval of such change.

The schedule shall be kept up to date, taking into account the actual progress of work and shall be updated, if necessary, every 30 calendar days. The updated schedule shall, as determined by the Engineer, be sufficient to meet the requirements for the completion of the separable parts of work and the entire projects as set forth in the contract.

Upon commencing work, the Contractor shall submit at the start of each week to the Engineer for review, a detailed three (3) week construction schedule.

- C. If at any time during the progress of the Work, the Contractor's actual progress appears to the Engineer to be inadequate to meet the requirements of the contract, the Engineer will notify the Contractor of such imminent or actual noncompliance with the contract. The Contractor shall thereupon take such steps as may be necessary to improve his progress and the Engineer may require an increase in the labor force, the number of shifts, and/or overtime operations, days of work and/or the amount of construction plants all without additional cost to the State. Neither such notice by the Engineer nor the Engineer's failure to issue such notice shall relieve the Contractor from his obligation to achieve the quality of work and rate of progress required by the contract. Failure of the Contractor to comply with instructions of the Engineer under these provisions may be grounds for determination by the State that the Contractor is not prosecuting work with such diligence as will assure completion within the times specified. Upon such determination, the State may employ labor and equipment and charge the Contractor for the cost thereof, including depreciation for plant and equipment or may terminate the Contractor's right to proceed with the performance of the contract, or any separable part thereof, in accordance with the applicable provisions of the contract.
- D. The Contractor shall submit to the Engineer one (1) reproducible and three (3) prints of the detailed construction schedule and of each revised schedule submitted thereafter.

#### 1.04 SCHEDULE OF VALUES

- A. The Contractor shall submit the Schedule of Values to the Engineer for

review, no later than 30 calendar days after award of the Contract.

- B. Format and Content: Use Proposal Schedule and/or the Project Specifications table of contents as a guide to establish the format for the Schedule of Values. Provide at least one line item for each Specification Section. Provide a breakdown of the contract sum in sufficient detail to facilitate continued evaluation of Applications for Payment and progress reports. Break principle work or subcontract amounts down into several smaller identifiable items of work.
- C. Identification: Include the following Project identification on the schedule of values:
  - 1. Project name and location
  - 2. Project number
  - 3. Contractor's name and address
  - 4. Contract No.
  - 5. Date of submittal
- D. Arrange the Schedule of Values in tabular form with separate columns to indicate the following items listed:
  - 1. Related Specification Section or Division
  - 2. Description of work
  - 3. Dollar value and percent complete
- E. Correlate line items in the Schedule of Values with other required administrative schedules and forms including;
  - 1. Construction Schedule
  - 2. Application for Payment forms including continuation sheets
  - 3. List of Subcontractors
  - 4. List of principle suppliers and fabricators
  - 5. Schedule of submittals
- F. Round amount to nearest whole dollar; the total shall equal the contract sum.
- G. Provide a separate line item in the Schedule of Values for each part of the

work where Applications for Payment may include materials or equipment, purchased, fabricated or stored, but not yet installed.

- H. Schedule Updating: Update and resubmit the Schedule of Values prior to the next Applications for Payment or when Change Orders or Construction Change Directives result in a change in the Contract Sum.

1.05 OTHER SUBMITTALS REQUIRED BEFORE CONSTRUCTION

The Contractor shall submit the following items prior to or at the pre-construction meeting or unless otherwise noted:

- A. Name, residence phone number, addresses and scope of authority for the following persons:
  - 1. Superintendent
  - 2. Contractor's authorized representative to sign documents
  - 3. Two (2) additional persons who can be contacted during non-working hours for emergencies.
  - 4. Field Office location and phone numbers (cellular, pager, fax, etc.)
- B. Name of Safety Officer
- C. Notice of Materials to be furnished
- D. Three (3) copies each of Certificates of Insurance. The State of Hawaii, Department of Transportation, Airports Division shall be named as additionally insured. The project number and project title shall be referenced in the Description of Operations/Locations/Vehicles. If canceled, 30 days written notice to the State of Hawaii must be given. If certificates are not correct, work cannot proceed.
- E. Three (3) copies each Insurance and Tax Rates.
- F. List of apprentices who will be working on the project supported with the Statement of Apprenticeship or copy of the Apprenticeship Agreements registered with the State Board, for each apprentice.
- G. List of equipment to be used on the job. Designate maximum working height and capacity of equipment involved and their respective rental rates.
- H. Three (3) copies of an expenditure (cash flow) plan consisting of an anticipated work completion graph plotting contract time and gross payment anticipated.

1.06 SHOP DRAWINGS, SAMPLES, CATALOG CUTS, AND CERTIFICATES

- A. Submittal Schedule: Prior to the submission of any shop drawings or submittals, the Contractor shall submit to the Engineer for review, a submittal schedule. The schedule shall identify the subject matter of each submittal, the corresponding specification section number and the proposed date of submission. During the progress of work, the Contractor shall revise and resubmit the submittal schedule as directed by the Engineer.
- B. The Contractor shall submit for review to the Engineer, or to a representative designated by the Engineer, six (6) copies of all shop drawings, samples, catalog cuts and certificates. Three (3) copies will be returned to the Contractor with information of review action. The Contractor shall submit additional quantities for their subcontractor's or supplier's use. Each shop drawing, certificate of compliance, sample, and equipment list shall be checked and certified correct by the Contractor and shall be identified with the applicable information specified hereinafter under "Submittal Identification."

Items are to be reviewed prior to commencing fabrication or delivery of material to the job site.

- C. Each copy of the drawings, certificates, catalog cuts, and lists reviewed by the Engineer will be stamped "REVIEW ACTION" with the appropriate action noted therein. The review of the Engineer shall not be construed as a complete check but will indicate only that the general method of construction and detailing is satisfactory. Acceptance of such drawings will not relieve the Contractor the responsibility of conforming to the contract drawings and specifications or for any error or omission which may exist as the Contractor shall be responsible for the dimensions and design of adequate connections, details, and satisfactory construction of all work. Each shop drawing submitted for review shall have, in the lower right-hand corner just above title, a white space 4" x 4" in which the Engineer can place the stamp and indicate action taken. The Contractor shall also inform their subcontractors to provide this space in their preparation of shop drawings.

1.07 MAINTENANCE DATA AND OPERATING INSTRUCTIONS

Six (6) copies of maintenance data and operating instructions shall be submitted by the Contractor at the conclusion of the equipment installation. The manuals shall be assembled in one or more binders, each with a title page, typed table of contents, and heavy section dividers with numbered plastic index tabs. The binders shall be a minimum of 2 inches thick, three ring, "D slant" with hard covers. All data shall be punched for binding and composition and printing shall be arranged so that punching does not obliterate any data. The project number, project title, and Airport shall be inserted in the front and backbone binder cover.

The Contractor shall submit a draft to the Engineer for review prior to the submission of the final copies.

The manual shall include separate sections describing each equipment. Provide a general description of the equipment, instructions for operation, maintenance, recommended inspection points and periods for inspection, testing, adjustments, calibration procedures with illustrations, wiring diagrams, trouble shooting situations and solutions, and repair methods in a practical, complete, and comprehensive manner.

For each equipment, include information on detailed parts listings (part numbers and costs) with the manufacturer's name, address, contact person, e-mail address and phone/fax numbers. Provide the contact name, address, e-mail address and phone/fax numbers of the distributor in the State of Hawaii for each equipment.

Include a separate section on warranty information on all products and equipment. Provide this information in a tabular format with a listing on all products and equipments with warranty start and completion dates for each item.

Include separate sections on all approved submittals, test reports, certifications, etc.

All information shall be arranged in a logical, orderly sequence. Manuals submitted by the manufacturer will not be accepted.

1.08 TEST REPORTS

Six copies of test reports for any material used in this Contract shall be submitted when specified or required by the Engineer.

1.09 SUBMITTAL IDENTIFICATION

A. To avoid rejection and to clarify each submittal, the General Contractor shall have a rubber stamp made up in the following format:

B. \_\_\_\_\_  
General Contractor's Name

PROJECT TITLE: \_\_\_\_\_

AIRPORT: \_\_\_\_\_

STATE PROJECT NO: \_\_\_\_\_

AIP PROJECT NO: \_\_\_\_\_

THIS SUBMITTAL HAS BEEN CHECKED BY THIS GENERAL  
CONTRACTOR AND IS CERTIFIED CORRECT AND IN  
COMPLIANCE WITH THE CONTRACT DRAWINGS AND

SPECIFICATIONS.

ITEM NO. \_\_\_\_\_

SUBMITTAL NUMBER \_\_\_\_\_

DATE RECEIVED \_\_\_\_\_

SPECIFICATION SECTION # \_\_\_\_\_

SPECIFICATION PARAGRAPH # \_\_\_\_\_

DRAWING NUMBER \_\_\_\_\_

SUBCONTRACTOR NAME \_\_\_\_\_

SUPPLIER NAME \_\_\_\_\_

MANUFACTURER NAME \_\_\_\_\_

CERTIFIED BY \_\_\_\_\_ (Contractor's Signature, Date)  
\_\_\_\_\_  
(Contractor's Name and Title)

- C. This stamp "filled in" should appear on each reproducible shop drawing, on the cover sheet of copies of test and mill reports, certificates of compliance, catalog cuts, brochures, etc. The stamp should be placed on a heavy stock paper merchandise (approximately 3" x 6") and one tag tied to each sample submitted for approval. The tag on the samples should state what the sample is, so that if the tag is accidentally separated from the sample, they can be matched up again. The back of this tag will be used by the Engineer for receipt, approval, and log stamp for any comments that relates to the sample.
- D. Submission Number: Each submission is to be sequentially numbered in the space provided in the Contractor's stamp. Correspondence and transmittal will refer to this number.
- E. The Contractor shall ensure that all submittals, including shop drawings, are complete and in conformance to the requirements of the Contract specifications prior to submission to the State for review and acceptance. Incomplete submittals will not be processed by the State and returned to the Contractor for correction. Any cost impacts and delays in the Project schedule as a result of incomplete submittals shall be the responsibility of the Contractor.

1.10 AS-BUILT DRAWINGS

As-built drawings shall conform to the requirements of Section 5.8 - "Coordination Between the Contractor and the State" of the General Provisions for Construction Projects (2016), and the following requirements:

The Contractor shall maintain on the job site a set of full-size contract drawings, marking them in red to show all variations between the construction actually provided and that indicated or specified in the contract documents, including buried or concealed construction. (Section 5.8 (a) Drawings and Special Provisions of the General Provisions for Construction Projects.)

Where a choice of material or method is permitted herein or where variations in scope of character of work from that of the original contract or authorized, the drawings shall be marked to define the construction actually provided. Where equipment installation is involved, the size, manufacturer's name, model number, power input or output characteristics as applicable shall be shown on the as-built drawings.

The representation of such changes shall conform to standard drafting practice and shall include such supplementary notes, legends, and details as necessary to clearly portray the as-built construction.

The drawings shall be maintained and updated on a daily basis. The Contractor shall stamp, sign, and date each sheet with the following stamp:

AS-BUILT DRAWINGS/SPECIFICATIONS

This certifies that the dimensions and details shown on this sheet reflect the dimensions and details, and specifications as constructed in the field.

---

CONTRACTOR'S NAME

---

Signature

Date

Monthly and final payments to the Contractor shall be subject to prior approval of the drawings. On completion of the work, both sets of marked-up drawings shall be delivered to the Engineer and shall be subject to approval before acceptance.

1.11 GUARANTEES

Guarantee periods shall start at time of acceptance in writing by the State.

All guarantees and warranties shall be made out to the "State of Hawaii." Supplier and subcontractor guarantees shall be co-signed by the Contractor.

The Contractor is solely responsible for coincidence or non-coincidence of factory warranties or equipment guarantees, and the Contractor's own warranties and guarantees as required by the contract. The Contractor is solely responsible for scheduling and coordinating the installation of equipment and materials so as to take maximum advantage of factory warranties.

PART 2 - PRODUCTS (Not Used)

PART 3 - EXECUTION (Not Used)

PART 4 - MEASUREMENT AND PAYMENT

4.01 BASIS OF MEASUREMENT AND PAYMENT

Work under this section will not be measured nor paid for separately but shall be considered incidental to and included in the bid prices for the various items of work in this project.

END OF SECTION

## SECTION 01400 - CONTRACTOR QUALITY CONTROL PROGRAM

### PART 1 - GENERAL

#### 1.01 RELATED DOCUMENTS

The General Provisions for Construction Projects (2016), Special Provisions and General Requirements of the Specifications, apply to the work specified in this Section.

#### 1.02 CONTRACTOR QUALITY CONTROL PROGRAM

##### A. GENERAL

The Contractor shall establish, provide, and maintain an effective Quality Control Program that details the methods and procedures that will be taken to assure that all materials and completed construction required by this contract conform to contract plans, technical specifications and other requirements, whether manufactured by the Contractor, or procured from subcontractors or vendors. Although guidelines are established and certain minimum requirements are specified herein and elsewhere in the contract technical specifications, the Contractor shall assume full responsibility for accomplishing the stated purpose.

The intent of this section is to enable the Contractor to establish a necessary level of control that will:

1. Adequately provide for the production of acceptable quality materials.
2. Provide sufficient information to assure both the Contractor and the Engineer that the specification requirements can be met.
3. Allow the Contractor as much latitude as possible to develop his or her own standard of control.

The Contractor shall be prepared to discuss and present, at the pre-construction conference, his/her understanding of the quality control requirements. The Contractor shall not begin any construction or production of materials to be incorporated into the completed work until the Quality Control Program has been reviewed and approved by the Engineer and State Project Manager. No partial payment will be made for materials subject to specific quality control requirements until the Quality Control Program has been reviewed and approved.

##### B. DESCRIPTION OF PROGRAM

1. General Description. The Contractor shall establish a Quality Control Program to perform inspection and testing of all items of

work required by the technical specifications, including those performed by subcontractors. This Quality Control Program shall ensure conformance to applicable specifications and plans with respect to materials, workmanship, construction, finish, and functional performance. The Quality Control Program shall be effective for control of all construction work performed under this Contract and shall specifically include surveillance and tests required by the technical specifications, in addition to other requirements of this section and any other activities deemed necessary by the Contractor to establish an effective level of quality control.

2. Quality Control Program. The Contractor shall describe the Quality Control Program in a written document which shall be reviewed and approved by the Engineer and State Project Manager prior to the start of any production, construction, or off-site fabrication. The written Quality Control Program shall be submitted to the Engineer for review no later than thirty (30) calendar days after award of the Contract.
3. The Quality Control Program shall be organized to address, as a minimum, the following items:
  - a. Quality control organization;
  - b. Submittals schedule;
  - c. Inspection requirements;
  - d. Quality control testing plan;
  - e. Documentation of quality control activities; and
  - f. Requirements for corrective action when quality control and/or acceptance criteria are not met.
  - g. A listing of the definable features of work for the project.

The Contractor is encouraged to add any additional elements to the Quality Control Program that he/she deems necessary to adequately control all production and/or construction processes required by this contract.

### C. QUALITY CONTROL ORGANIZATION

The Contractor's Quality Control Program shall be implemented by the establishment of a separate quality control organization that is not a part of the production organization. An organizational chart shall be developed to show all quality control personnel and how these personnel

integrate with other management/production and construction functions and personnel. The organizational chart shall identify all quality control staff by name and function and shall indicate the total staff required to implement all elements of the Quality Control Program, including inspection and testing for each item of work. At the top of the chart, an overall Contractor Quality Control System Manager, CQCSM, shall be named and his/her subordinates shall follow thereafter.

The quality control organization shall consist of the following minimum personnel:

1. Contractor Quality Control System Manager. The CQCSM shall be a full-time employee of the Contractor, or a consultant engaged by the Contractor. The CQCSM shall have a minimum of 5 years of experience in airport and/or paving and building construction and shall have had prior quality control experience on a project of comparable size and scope as the contract. The CQCSM shall be on the project full time and shall have no production duties. The CQCSM shall NOT be the point of contact for the production organization.

The CQCSM shall have full authority to institute any and all actions necessary for the successful implementation of the Quality Control Program to ensure compliance with the contract plans and technical specifications including authority to independently stop any work not in compliance with the contract. The CQCSM shall report directly to a responsible officer of the construction firm, such officer not being the project superintendent or foreman. The CQCSM may supervise the Quality Control Program on more than one project provided that person can be at the job site within 2 hours after being notified of a problem and a Quality Control Technician is present on the job site full time.

2. Quality Control Technicians. A sufficient number of quality control technicians necessary to adequately implement the Quality Control Program shall be provided. These personnel shall be either engineers, engineering technicians, or experienced craftsman with qualifications in the appropriate fields and shall have a minimum of 2 years of experience in their area of expertise.

The quality control technicians shall report directly to the CQCSM and shall perform the following functions:

- a. Inspection of all materials, construction, plant, and equipment for conformance to the technical specifications, and as required by Section 1.02E.
- b. Performance of all quality control tests as required by the technical specifications and Section 1.02F.

3. Staffing. The Contractor shall provide sufficient qualified quality control personnel to monitor each work activity at all times. The scheduling and coordinating of all inspection and testing must match the type and pace of work activity. The Quality Control Program shall state where different technicians will be required for different work elements.

All personnel shown on the organizational chart shall have, in resume form, all information regarding their education, any licenses, their present position, previous work experience, etc. included in the Quality Control Program written documentation. These resumes shall be verified by the CQCSM.

D. SUBMITTALS SCHEDULE

The Contractor shall submit a detailed listing of all submittals (e.g., mix designs, material certifications, color samples) and shop drawings required by the technical specifications. The listing can be developed in a spreadsheet format and shall include:

1. Specification item number;
2. Item description;
3. Description of submittal;
4. Specification paragraph requiring submittal; and
5. Scheduled date of submittal.

E. INSPECTION REQUIREMENTS

Quality control inspection functions shall be organized to provide inspections for all definable features of work, as detailed below. All inspections shall be documented by the Contractor.

Inspections shall be performed daily to ensure continuing compliance with contract requirements until completion of the particular feature of work.

Before any definable feature of work is started, the CQCSM shall notify the Engineer and State Project Manager of such work at least 48 hours in advance. Upon notification, the Engineer or State Project Manager shall determine if a meeting shall be held to discuss the condition of the work area, material and equipment status, what is to be expected and any questions or possible problems. No definable feature work shall commence without the consent of the Engineer and State Project Manager.

F. QUALITY CONTROL TESTING PLAN

As a part of the overall Quality Control Program, the Contractor shall implement a quality control testing plan, as required by the technical specifications. The testing plan shall include the minimum tests and test frequencies required by each technical specification item, as well as any additional quality control tests that the Contractor deems necessary to adequately control production and/or construction processes.

The testing plan can be developed in a spreadsheet fashion and shall, as a minimum, include the following:

1. Specification item number;
2. Item description (e.g., concrete cylinder test);
3. Test type (e.g., concrete compressive strength);
4. Test standard (e.g., ASTM or AASHTO test number, as applicable);
5. Test frequency (e.g., as required by technical specifications or minimum frequency when requirements are not stated);
6. Responsibility (e.g., plant technician, independent lab); and
7. Control requirements (e.g., target, permissible deviations).

The testing plan shall contain a statistically based procedure of random sampling for acquiring test samples in accordance with ASTM D 3665. The Engineer and State Project Manager shall be provided the opportunity to witness quality control sampling and testing. The CQCSM shall make every effort to inform the Engineer and State Project Manager at least 24 hours, or more if stated in the specifications, before such testing occurs.

All quality control test results shall be documented by the Contractor as required by Section 1.02G.

G. DOCUMENTATION

The Contractor shall maintain current quality control records of all inspections and tests performed. These records shall include factual evidence that the required inspections or tests have been performed, including type and number of inspections or tests involved; results of inspections or tests; nature of defects, deviations, causes for rejection, etc.; proposed remedial action; and corrective actions taken.

These records must cover both conforming and defective or deficient features, and must include a statement that all supplies and materials

incorporated in the work are in full compliance with the terms of the contract. Legible copies of these records shall be furnished to the Engineer and State Project Manager daily. The records shall cover all work placed subsequent to the previously furnished records and shall be verified and signed by the CQCSM.

Specific Contractor quality control records required for the contract shall include, but are not necessarily limited to, the following records:

1. Daily Inspection Reports. Each Contractor quality control technician shall maintain a daily log of all inspections performed for both Contractor and Subcontractor operations on a form acceptable to the Engineer and State Project Manager. These technician's daily reports shall provide factual evidence that continuous quality control inspections have been performed and shall, as a minimum, include the following:
  - a. Technical specification item number and description and location of work performed;
  - b. A comprehensive breakdown of the work force including the number of workers and total hours for each trade.
  - c. Compliance with approved submittals;
  - d. Proper storage of materials and equipment;
  - e. Proper operation of all equipment;
  - f. Adherence to plans and technical specifications;
  - g. Review of quality control tests; and
  - h. Safety inspection.

The daily inspection reports shall identify inspections conducted, results of inspections, location and nature of defects found, causes for rejection, and remedial or corrective actions taken or proposed.

The daily inspection reports shall be signed by the responsible quality control technician and the CQCSM. The Engineer and State Project Manager shall be provided at least one copy of each daily inspection report on the workday following the day of record.

2. Daily Test Reports. The Contractor shall be responsible for establishing a system which will record all quality control test results. Daily test reports shall document the following information:
  - a. Technical specification item number and description;

- b. Test designation;
- c. Location;
- d. Date of test;
- e. Control requirements;
- f. Test results;
- g. Causes for rejection;
- h. Recommended remedial actions; and
- i. Retests.

Test results from each day's work period shall be submitted to the Engineer and State Project Manager prior to the start of the next day's work period. When required by the technical specifications, the Contractor shall maintain statistical quality control charts. The daily test reports shall be signed by the responsible quality control technician and the CQCSM.

#### H. CORRECTIVE ACTION REQUIREMENTS

The Quality Control Program shall indicate the appropriate action to be taken when a process is deemed, or believed, to be out of control (out of tolerance) and detail what action will be taken to bring the process into control. The requirements for corrective action shall include both general requirements for operation of the Quality Control Program as a whole, and for individual items of work contained in the technical specifications.

The Quality Control Program shall detail how the results of quality control inspections and tests will be used for determining the need for corrective action and shall contain clear sets of rules to gauge when a process is out of control and the type of correction to be taken to regain process control.

When applicable or required by the technical specifications, the Contractor shall establish and utilize statistical quality control charts for individual quality control tests. The requirements for corrective action shall be linked to the control charts.

#### I. SURVEILLANCE BY THE ENGINEER AND STATE PROJECT MANAGER

All items of material and equipment shall be subject to surveillance by the Engineer or State Project Manager at the point of production, manufacture or shipment to determine if the Contractor, producer,

manufacturer or shipper maintains an adequate quality control system in conformance with the requirements detailed herein and the applicable technical specifications and plans. In addition, all items of materials, equipment and work in place shall be subject to surveillance by the Engineer or State Project Manager at the site for the same purpose.

Surveillance by the Engineer or State Project Manager does not relieve the Contractor of performing quality control inspections of either on-site or off-site Contractor's or subcontractor's work.

J. NONCOMPLIANCE

1. The Engineer or State Project Manager will notify the Contractor of any noncompliance with any of the foregoing requirements. The Contractor shall, after receipt of such notice, immediately take corrective action. Any notice, when delivered by the Engineer or State Project Manager or his/her authorized representative to the Contractor or his/her authorized representative at the site of the work, shall be considered sufficient notice.
2. In cases where quality control activities do not comply with either the Contractor's Quality Control Program or the Contract provisions, or where the Contractor fails to properly operate and maintain an effective Quality Control Program, as determined by the Engineer or State Project Manager, the Engineer or State Project Manager may:
  - a. Order the Contractor to replace ineffective or unqualified quality control personnel or subcontractors in accordance with Section 8.4 – “Character and Proficiency of Workers” of the General Provisions for Construction Projects (2016).
  - b. Order the Contractor to stop operations in accordance with Section 8.10 – “Suspension of Work” of the General Provisions for Construction Projects (2016).
  - c. Determine work performed by the Contractor during periods of noncompliance to be unacceptable and subject to inspection, removal or non-payment in accordance with Section 5.12 – “Removal of Non-Conforming and Unauthorized Work: Performance of Corrective or Remedial Work” of the General Provisions for Construction Projects (2016).

PART 2 - PRODUCTS (Not Used)

PART 3 - EXECUTION (Not Used)

PART 4 – MEASUREMENT AND PAYMENT

4.01 BASIS OF MEASUREMENT AND PAYMENT

Work under this section will not be measured nor paid for separately but shall be considered incidental to and included in the prices bid for the various items of work in this project.

END OF SECTION

## SECTION 01524 - CONSTRUCTION WASTE MANAGEMENT

### PART 1 - GENERAL

#### 1.01 RELATED DOCUMENTS

The General Provisions for Construction Projects (2016), Special Provisions and General Requirements of the Specifications, apply to the work specified in this Section.

#### 1.02 SUMMARY

- A. Section includes administrative and procedural requirements for the following:
1. Salvaging nonhazardous demolition and construction waste.
  2. Recycling nonhazardous demolition and construction waste.
  3. Disposing of nonhazardous demolition and construction waste.

#### 1.03 DEFINITIONS

- A. Construction Waste: Building and site improvement materials and other solid waste resulting from construction, remodeling, renovation, or repair operations. Construction waste includes packaging.
- B. Demolition Waste: Building and site improvement materials resulting from demolition or selective demolition operations.
- C. Disposal: Removal off-site of demolition and construction waste and subsequent sale, recycling, reuse, or deposit in landfill or incinerator acceptable to authorities having jurisdiction.
- D. Recycle: Recovery of demolition or construction waste for subsequent processing in preparation for reuse.
- E. Salvage: Recovery of demolition or construction waste and subsequent sale or reuse in another facility.
- F. Salvage and Reuse: Recovery of demolition or construction waste and subsequent incorporation into the Work.

#### 1.04 PERFORMANCE REQUIREMENTS

- A. General: Practice efficient waste management in the use of materials in the course of the Work. Use all reasonable means to divert construction and demolition waste from landfills and incinerators. Facilitate recycling and salvage of materials, including the following:
1. Demolition Waste:

- a. Asphaltic concrete paving
- b. Concrete
- c. Equipment
- d. Wiring

2. Construction Waste:

- a. Packaging: Regardless of salvage/recycle goal indicated in "General" Paragraph above, salvage or recycle 100 percent of the following uncontaminated packaging materials:
  - 1) Paper.
  - 2) Cardboard.
  - 3) Boxes.
  - 4) Plastic sheet and film.
  - 5) Polystyrene packaging.
  - 6) Wood crates.
  - 7) Plastic pails.
  - 8) Conductors.

1.05 ACTION SUBMITTALS

- A. Waste Management Plan: Submit plan within fourteen (14) days of date established for the Notice to Proceed.

1.06 INFORMATIONAL SUBMITTALS

- A. Waste Reduction Progress Reports: Concurrent with each Application for Payment, submit report. Include the following information:
  - 1. Material category.
  - 2. Generation point of waste.
  - 3. Total quantity of waste in tons.
  - 4. Quantity of waste salvaged, both estimated and actual in tons.
  - 5. Quantity of waste recycled, both estimated and actual in tons.
  - 6. Total quantity of waste recovered (salvaged plus recycled) in tons.
  - 7. Total quantity of waste recovered (salvaged plus recycled) as a percentage of total waste.
- B. Waste Reduction Calculations: Before request for Substantial Completion, submit calculated end-of-Project rates for salvage, recycling, and disposal as a percentage of total waste generated by the Work.
- C. Records of Donations: Indicate receipt and acceptance of salvageable waste donated to individuals and organizations. Indicate whether organization is tax exempt.
- D. Records of Sales: Indicate receipt and acceptance of salvageable waste sold to individuals and organizations. Indicate whether organization is tax exempt.

- E. Recycling and Processing Facility Records: Indicate receipt and acceptance of recyclable waste by recycling and processing facilities licensed to accept them. Include manifests, weight tickets, receipts, and invoices.
- F. Landfill and Incinerator Disposal Records: Indicate receipt and acceptance of waste by landfills and incinerator facilities licensed to accept them. Include manifests, weight tickets, receipts, and invoices. The Honolulu Program of Waste Energy Recovery (H- POWER) by the City and County of Honolulu is the only acceptable incinerator in Oahu.
- G. Statement of Refrigerant Recovery: Signed by refrigerant recovery technician responsible for recovering refrigerant, stating that all refrigerant that was present was recovered and that recovery was performed according to EPA regulations. Include name and address of technician and date refrigerant was recovered.

#### 1.07 QUALITY ASSURANCE

- A. Refrigerant Recovery Technician Qualifications: Certified by EPA-approved certification program.
- B. Regulatory Requirements: Comply with hauling and disposal regulations of authorities having jurisdiction.
- C. Waste Management Conference: Conduct conference at Project site to comply with requirements. Review methods and procedures related to waste management including, but not limited to, the following:
  - 1. Review requirements for documenting quantities of each type of waste and its disposition.
  - 2. Review and finalize procedures for materials separation and verify availability of containers and bins needed to avoid delays.
  - 3. Review procedures for periodic waste collection and transportation to recycling and disposal facilities.
  - 4. Review waste management requirements for each trade.

#### 1.08 WASTE MANAGEMENT PLAN

- A. General: Develop a waste management plan according to ASTM E 1609 and requirements in this Section. Plan shall consist of waste identification, waste reduction work plan, and cost/revenue analysis.
- B. Waste Reduction Work Plan: List each type of waste and whether it will be salvaged, recycled, or disposed of in landfill or incinerator. Include points of waste generation, total quantity of each type of waste, quantity for each means

of recovery, and handling and transportation procedures.

1. Salvaged Materials for Reuse: For materials that will be salvaged and reused in this Project, describe methods for preparing salvaged materials before incorporation into the Work.
2. Salvaged Materials for Sale: For materials that will be sold to individuals and organizations, include list of their names, addresses, and telephone numbers.
3. Recycled Materials: Include list of local receivers and processors and type of recycled materials each will accept. Include names, addresses, and telephone numbers.
4. Disposed Materials: Indicate how and where materials will be disposed of. Include name, address, and telephone number of each landfill and incinerator facility.
5. Handling and Transportation Procedures: Include method that will be used for separating recyclable waste including sizes of containers, container labeling, and designated location where materials separation will be performed.

## PART 2 – PRODUCTS (Not Used)

## PART 3 - EXECUTION

### 3.01 PLAN IMPLEMENTATION

- A. General: Implement approved waste management plan. Provide handling, containers, storage, signage, transportation, and other items as required to implement waste management plan during the entire duration of the Contract.
- B. Training: Train workers, subcontractors, and suppliers on proper waste management procedures, as appropriate for the Work.
  1. Distribute waste management plan to everyone concerned within three days of submittal return.
  2. Distribute waste management plan to entities when they first begin work on-site. Review plan procedures and locations established for salvage, recycling, and disposal.
- C. Site Access and Temporary Controls: Conduct waste management operations to ensure minimum interference with roads, streets, walks, walkways, and other adjacent occupied and used facilities.
  1. Designate and label specific areas on Project site necessary for separating materials that are to be salvaged, recycled, reused, donated,

and sold.

### 3.02 SALVAGING DEMOLITION WASTE

- A. Salvaged Items for Reuse in the Work: Salvage items for reuse and handle as follows:
  - 1. Clean salvaged items.
  - 2. Pack or crate items after cleaning. Identify contents of containers with label indicating elements, date of removal, quantity, and location where removed.
  - 3. Store items in a secure area until installation.
  - 4. Protect items from damage during transport and storage.
  - 5. Install salvaged items to comply with installation requirements for new materials and equipment. Provide connections, supports, and miscellaneous materials necessary to make items functional for use indicated.
- B. Salvaged Items for Sale: Not permitted on Project site.
- C. Salvaged Items for Owner's Use: Salvage items for Owner's use and handle as follows:
  - 1. Clean salvaged items.
  - 2. Pack or crate items after cleaning. Identify contents of containers with label indicating elements, date of removal, quantity, and location where removed.
  - 3. Store items in a secure area until delivery to Owner.
  - 4. Transport items to Owner's storage area designated by Owner.
  - 5. Protect items from damage during transport and storage.

### 3.03 RECYCLING DEMOLITION AND CONSTRUCTION WASTE, GENERAL

- A. General: Recycle paper and beverage containers used by on-site workers.
- B. Preparation of Waste: Prepare and maintain recyclable waste materials according to recycling or reuse facility requirements. Maintain materials free of dirt, adhesives, solvents, petroleum contamination, and other substances deleterious to the recycling process.
- C. Procedures: Separate recyclable waste from other waste materials, trash, and

debris. Separate recyclable waste by type at Project site to the maximum extent practical according to approved construction waste management plan.

1. Provide appropriately marked containers or bins for controlling recyclable waste until removed from Project site. Include list of acceptable and unacceptable materials at each container and bin.
  - a. Inspect containers and bins for contamination and remove contaminated materials if found.
2. Stockpile processed materials on-site without intermixing with other materials. Place, grade, and shape stockpiles to drain surface water. Cover to prevent windblown dust.
3. Stockpile materials away from construction area. Do not store within drip line of remaining trees.
4. Store components off the ground and protect from the weather.
5. Remove recyclable waste from Owner's property and transport to recycling receiver or processor.

#### 3.04 RECYCLING DEMOLITION WASTE

- A. Asphalt Paving: Break up and transport paving to asphalt-recycling facility or crush asphaltic concrete paving and screen.
- B. Concrete: Break up and transport paving to concrete recycling facility or crush concrete and screen.
- C. Concrete: Remove reinforcement and other metals from concrete and sort with other metals.
- D. Masonry: Remove metal reinforcement, anchors, and ties from masonry and sort with other metals.
- E. Wood Materials: Sort and stack members according to size, type, and length. Separate lumber, engineered wood products, panel products, and treated wood materials.
- F. Metals: Separate metals by type.
  1. Structural Steel: Stack members according to size, type of member, and length.
  2. Remove and dispose of bolts, nuts, washers, and other rough hardware.
- G. Asphalt Shingle Roofing: Separate organic and glass-fiber asphalt shingles and felts. Remove and dispose of nails, staples, and accessories.

- H. Gypsum Board: Stack large clean pieces on wood pallets or in container and store in a dry location. Remove edge trim and sort with other metals. Remove and dispose of fasteners.
- I. Acoustical Ceiling Panels and Tile: Stack large clean pieces on wood pallets and store in a dry location.
- J. Metal Suspension System: Separate metal members including trim, and other metals from acoustical panels and tile and sort with other metals.
- K. Carpet and Pad: Roll large pieces tightly after removing debris, trash, adhesive, and tack strips.
  - 1. Store clean, dry carpet and pad in a closed container or trailer provided by Carpet Reclamation Agency or carpet recycler.
- L. Carpet Tile: Remove debris, trash, and adhesive.
  - 1. Stack tile on pallet and store clean, dry carpet in a closed container or trailer provided by Carpet Reclamation Agency or carpet recycler.
- M. Piping: Reduce piping to straight lengths and store by type and size. Separate supports, hangers, valves, sprinklers, and other components by type and size.
- N. Conduit: Reduce conduit to straight lengths and store by type and size.

### 3.05 RECYCLING CONSTRUCTION WASTE

- A. Packaging:
  - 1. Cardboard and Boxes: Break down packaging into flat sheets. Bundle and store in a dry location.
  - 2. Polystyrene Packaging: Separate and bag materials.
  - 3. Pallets: As much as possible, require deliveries using pallets to remove pallets from Project site. For pallets that remain on-site, break down pallets into component wood pieces and comply with requirements for recycling wood.
  - 4. Crates: Break down crates into component wood pieces and comply with requirements for recycling wood.
- B. Wood Materials:
  - 1. Clean Cut-Offs of Lumber: Grind or chip into small pieces.
  - 2. Clean Sawdust: Bag sawdust that does not contain painted or treated

wood.

- C. Gypsum Board: Stack large clean pieces on wood pallets or in container and store in a dry location.

3.06 DISPOSAL OF WASTE

- A. General: Except for items or materials to be salvaged, recycled, or otherwise reused, remove waste materials from Project site and legally dispose of them in a landfill or incinerator acceptable to authorities having jurisdiction. The Honolulu Program of Waste Energy Recovery (H-POWER) by the City and County of Honolulu is the only acceptable incinerator.
  - 1. Except as otherwise specified, do not allow waste materials that are to be disposed of accumulate on-site.
  - 2. Remove and transport debris in a manner that will prevent spillage on adjacent surfaces and areas.
  - 3. H-POWER will take the architectural canopy fabric made of mostly vinyl. Contractor can contact Scale House at 808-682-0261. H-POWER requires an account with Contractor.
- B. Burning: Do not burn waste materials in Airport ground.
- C. Disposal: Remove waste materials from Owner's property and legally dispose of them.

PART 4 - METHOD OF MEASUREMENT AND BASIS OF PAYMENT

4.01 BASIS OF MEASUREMENT AND PAYMENT

- A. Work under this section will not be measured for payment but will be paid for at the Contract Lump Sum Price.

<u>Item No.</u>	<u>Item</u>	<u>Unit</u>
01524.1	Construction Waste Management	Lump Sum

END OF SECTION

STATE OF HAWAII  
DEPARTMENT OF TRANSPORTATION  
HONOLULU, HAWAII

**SPECIFICATIONS**

**SECTION 01524 - CONSTRUCTION WASTE MANAGEMENT**

**APPENDIX A**

TABLE 1: WASTE IDENTIFICATION

Material	Est. Qty.	Est. tons*	Point of Generation	Comments/Assumptions

\* Avg volume-to-weight conversions are:

Mixed waste 5.7 yds/ton

Wood 6.7 yds/ton

Cardboard 20 yds/ton

Drywall 4 yds/ton

Rubble 1.4 yds/ton

TABLE 2: WASTE REDUCTION WORK PLAN

Material	S/R/D*	Est Qty S/R/D (tons)	Actual Qty S/R/D(tons)	Handling and Transport Procedures	Destination (Name, address, phone)**

\*S Salvage/Reuse  
 R Recycle  
 D Dispose

\*\* For materials sent for recycling or disposal, send to facilities currently permitted by the DOH, Solid Waste Section (808) 586-4226.  
 No solid waste management permit required for on-site processing of clean waste concrete, provided the processed product meets the "inert fill material" definition in Chapter 342H, HRS.  
 Solid Waste Management Permit required if destination site accepts for processing such waste materials (eg. Clean waste concrete) from other sites.

**TABLE 3: COST/REVENUE ANALYSIS**

Material	Est Cost of Disposal(1)	Est Revenue from Salvage/Recycle(2)	Est Cost of Salvage/Recycle(3)	Est Net Savings/Cost (1)+(2)-(3)

## SECTION 01560 - ENVIRONMENTAL CONTROLS

### PART 1 – GENERAL

#### 1.01 RELATED DOCUMENTS

- A. The General Provisions, Special Provisions, and Technical Provisions, apply to the work specified in this section. Special attention is directed to the following Articles:
1. State of Hawaii, Air and Water Transportation Facilities Division, General Provisions for Construction Projects, Article VI, Control of Materials, Paragraph 6.8 Non-Conforming Materials.
  2. State of Hawaii, Air and Water Transportation Facilities Division, General Provisions for Construction Projects, Article VII, Legal Relations and Responsibility to Public, Paragraph 7.14 Pollution Control and Protection of Archeological Historical, and Burial Sites.
  3. State of Hawaii, Air and Water Transportation Facilities Division, General Provisions for Construction Projects, Article VII, Legal Relations and Responsibility to Public, Paragraph 7.17 Contaminated or Hazardous Items and Material; Regulated Items and Material; Waste.
  4. Section 01561 Construction Site Runoff Control Program.
  5. Section 01562 Management of Contaminated Medias.
- B. The latest version of the State of Hawaii, Department of Transportation, Airports Division (DOTA) Construction Activities BMP Field Manual.

#### 1.02 ENVIRONMENTAL PROTECTION

With the exception of those measures set forth elsewhere in these specifications, environmental protection shall consist of the prevention of environmental pollution as the result of construction operations under this contract. For the purpose of this specification, environmental pollution is defined as the presence of chemical, physical, or biological elements or agents which adversely affect human health or welfare, unfavorably alter ecological balances of importance to human life, affect other species of importance to man, or degrade the utilization of the environment for aesthetic and recreational purposes.

#### 1.03 APPLICABLE REGULATIONS

In order to provide abatement and control of environmental pollution arising from the construction activities of the Contractor and their Subcontractors in

the performance of this contract, the work performed shall comply with the intent of all applicable Federal, State, and Local laws and regulations concerning environmental pollution control and abatement, including, but not limited to, the following regulations:

- A. State of Hawaii, Department of Health, Administrative Rules, Chapter 55, WATER POLLUTION CONTROL; Chapter 54, WATER QUALITY STANDARDS.
- B. State of Hawaii, Department of Health, Administrative Rules, Chapter 59, AMBIENT AIR QUALITY, Chapter 60.1, AIR POLLUTION CONTROL.
- C. State of Hawaii, Department of Health, Administrative Rules, Chapter 42, VEHICULAR NOISE CONTROL.
- D. State of Hawaii, Department of Health, Administrative Rules, Chapter 46, COMMUNITY NOISE CONTROL.
- E. State of Hawaii, Occupational Safety and Health Standards, Title 12, Department of Labor and Industrial Relations, Subtitle 8, Division of Occupational Safety and Health, Part 3 Construction Standards, Chapter 145 Asbestos.
- F. Environmental Protection Agency, Code of Federal Regulations Title 40, Part 61, Subpart M (Revised Subpart B), NATIONAL EMISSION STANDARDS FOR AIR POLLUTANTS and Subpart B, NATIONAL EMISSION STANDARDS FOR ASBESTOS; Final Rule dated November 20, 1990.
- G. U.S. Department of Labor - Occupational Safety and Health Administration (OSHA) Asbestos Regulations, Code of Federal Regulations Title 29, Parts 1910, 1915 and 1926, Occupational Exposure to Asbestos, Final Rule dated August 10, 1994.

### 1.03 SUBMITTALS

The Contractor shall submit the following items within thirty (30) calendar days after the Notice to Proceed Date:

- A. Submit proposed means, methods, techniques and procedures to be used for environmental control.

### PART 2 – PRODUCTS (NOT USED)

### PART 3 – EXECUTION

#### 3.01 AIR POLLUTION CONTROL

- A. Emission: The Contractor shall not be allowed to operate equipment and vehicles that show excessive emissions of exhaust gases until corrective repairs or adjustments are made, as determined by the Engineer.
- B. Dust: The Contractor, for the duration of the contract, shall maintain all excavations, embankments, haul roads, permanent access roads, plant sites, waste disposal areas, borrow areas, and all other work areas within or without the project limits free from dust which would cause a hazard to the work or operations of other Contractors, or to persons or property. Industry-accepted methods of stabilization suitable for the area involved, such as sprinkling or similar methods, will be permitted. Chemical or oil treating shall not be used.
- C. Burning on Airport property shall not be permitted.

### 3.02 WATER POLLUTION CONTROL

- A. Wastes: The Contractor shall not deposit, at the airport site or in its vicinity, solid waste or discharge liquid waste, such as fuels, lubricants, bituminous waste, untreated sewage, and other pollutants which may contaminate the body of ground water.
- B. Spillages: Care shall be taken to ensure that no petroleum products, bituminous materials, or other deleterious substances, including debris, are allowed to fall, flow, leach, or otherwise enter the sewage systems or storm drains.
- C. Erosion: The Contractor shall provide any necessary temporary drainage, dikes, and similar facilities to prevent erosion damage to the site. Run-off shall be controlled to prevent damage to the surrounding area.

### 3.03 NOISE CONTROL

- A. At all times keep objectionable noise generation to a minimum by:
  - 1. Equipping air compressors with silencing packages.
  - 2. Equipping jackhammers with silencers on the air outlet.
  - 3. Equipment that can be electrically driven instead of gas or diesel is preferred. If noise levels on equipment cannot reasonably be brought down to criteria, listed as follows, either the equipment will not be allowed on the job or use time will have to be scheduled subject to approval of the Engineer.
  - 4. All construction vehicles and equipment on the project operating between 10:00 p.m. and 7:00 a.m. shall be equipped with an

ambient noise sensing variable volume backup alarm system. The system shall be in compliance with Title 29 of the Code of Federal Regulations, Part 1926.601(b)(4)(i).

- B. Objectionable noise received on neighboring properties is defined as any noise exceeding the noise limits of State Regulations (Title 11, Hawaii Administrative Regulations, Department of Health, Chapter 46 – Community Noise Control) or City and County of Honolulu ordinance, as stated below, or as any noise causing a public nuisance in a residential area, as determined by the State and community representatives, or by the nuisance provisions of local ordinances.
  - 1. The noise limitations established are as set forth in the following table after any applicable adjustments provided for herein are applied:

RECEIVING PROPERTY

<u>Noise Source</u>	<u>Residential</u>	<u>Commercial</u>	<u>Industrial</u>
Airport	50 dBA	65 dBA	70 dBA

- 2. Between the hours of 6:00 p.m. to 5:00 a.m. on weekdays and weekends, the noise limitations above may be exceeded for any receiving property by no more than:
      - a. Five (5) dBA for a total of fifteen (15) minutes in any one (1) hour period; or
      - b. Ten (10) dBA for a total of five (5) minutes in any one (1) hour period; or
      - c. Fifteen (15) dBA for a total of one and one half (1.5) minutes in any one (1) hour period.
- C. In addition to the noise controls specified, demolition and construction activities conducted within 1,000 feet of residential areas may have additional noise controls required.
- D. The Contractor and its subcontractor operations shall, at all times, comply with all State of Hawaii and City and County of Honolulu requirements.
- E. For work conducted within Airport buildings, noise levels from work activities shall not exceed 85 dBA on the slow scale at the project boundary.

3.04 DISPOSAL

Contractor shall adhere to Construction Waste Management Section 01524. Construction rubbish shall be properly disposed of at a licensed landfill.

Please consult with the local landfill to ensure that objects meet the specific landfill's requirements for size, type, etc. Other areas or methods proposed by the Contractor will be approved only if the Engineer determines that their effect on the environment is equal to or less than those described herein.

### 3.05 HAZARDOUS MATERIALS CONTROL

A. The use of hazardous materials, i.e., asbestos and PCB, in the construction of this project shall be strictly prohibited. Any corrective action to remove and replace the hazardous material and contaminated work shall be at the sole expense of the Contractor.

#### B. DEFINITIONS

1. HAZARDOUS SUBSTANCE – Any substance designated pursuant to Section 311(b)(2)(A) of the Clean Water Act; any element, compound, mixture, solution, or substance designated pursuant to Section 102 of the Comprehensive Environmental Response, Compensation, and Liability Act (CERCLA); any hazardous waste having the characteristics identified under or listed pursuant to Section 3001 of the Solid Waste Disposal Act; any toxic pollutant listed under Section 307(a) of the Clean Water Act; any hazardous air pollutant listed under Section 112 of the Clean Air Act, as amended (42 U.S.C. §§7401-7626); any imminently hazardous chemical substance or mixture regulated under Section 7 of the Toxic Substances Control Act, as amended (15 U.S.C. §§2601-2671), oil, trichloro propane, and any other substance or pollutant or contaminant designated by rules adopted pursuant to this chapter (Chapter 128D, Hawaii Revised Statutes)
2. OIL – Oil Waste of any kind or in any form, including, but not limited to, petroleum, fuel oil, sludge, oil refuse, oil mixed with waste, crude oil, or any fraction or residue.
3. POLLUTANT OR CONTAMINANT – Any element, substance, compound, or mixture, which after release into the environment and upon exposure, ingestion, inhalation, or assimilation into any organism either directly from the environment or indirectly by ingestion through food chains, will or may reasonably be anticipated to cause death, disease, behavioral abnormalities, cancer, genetic mutation, physiological malfunctions (including malfunctions in reproduction) or physical deformation, in such organism or their offspring.

## PART 4 – MEASUREMENT AND PAYMENT

### 4.01 BASIS OF MEASUREMENT AND PAYMENT

All work specified in this Section shall not be measured nor paid for separately but shall be considered incidental and included in the prices bid for the various items of work in this project.

END OF SECTION

## SECTION 01561 – CONSTRUCTION SITE RUNOFF CONTROL PROGRAM

### PART 1 – GENERAL

#### 1.1 DESCRIPTION

This Section describes the following:

- (A) The Contractor shall comply with the following referenced documents:
- State of Hawaii, Department of Transportation, Airports Division (DOTA) Construction Activities Best Management Practices (BMP) Field Manual, in developing, installing, and maintaining Site-Specific BMPs for all projects.
  - DOTA's Storm Water Programs (SWMPP) for the Daniel K. Inouye International Airport (HNL) and Kahului Airport (OGG), as applicable.
  - Hawaii Administrative Rules (HAR) Chapters 11-54, 11-55, and 11-60.
  - Honolulu's City and County "Rules Relating to Water Quality" for all projects on Oahu. Use respective Soil Erosion Guidelines for Maui, Kauai and Hawaii projects.
  - Applicable Federal, State and Local Permit Conditions.
  - All other documents referenced in this Section.

For any conflicting requirements between the referenced documents and applicable bid documents, the stricter requirement will prevail and govern. Should a requirement not be clearly described within the applicable bid documents, notify the Engineer immediately for interpretation. For the purposes of clarification, "applicable bid documents" include the construction plans, specifications, and Permits.

- (B) Detailed plans, diagrams, and written Site-Specific Best Management Practices (BMPs); construction, maintenance, and repair of temporary water pollution, dust, and erosion control measures at the project site, including local material sources, work areas, and haul roads; removal and disposal of hazardous wastes; control of fugitive dust (defined as uncontrolled emission of solid airborne particulate matter from any source other than combustion).
- (C) Work associated with construction stormwater, dewatering, and hydrotesting activities and compliance with conditions of the Notice of General Permit Coverage (NGPC) or National Pollutant Discharge Elimination System (NPDES) permit(s) authorizing discharges associated with construction stormwater, dewatering, and hydrotesting activities.
- (D) Potential pollutant identification and mitigation measures, listed in Appendix A for use in the development of the Contractor's Site-Specific BMP.

Requirements of this Section also apply to construction support activities including: concrete or asphalt batch plants, rock crushing plants, equipment staging yards/areas, material storage areas, excavated material disposal areas, and borrow areas located both inside and outside of the Airport Property and State Right-of-Way. For areas serving multiple construction projects or operating beyond the completion of the construction project in which it supports, the Contractor shall be responsible for securing the necessary permits, clearances, and documents, and following the conditions of the permits and clearances, at no cost to the State.

The Contractor shall be responsible for all applicable subcontractors, suppliers and vendors, and shall ensure that the means and methods of construction activities of applicable subcontractors, suppliers and vendors are in full compliance with this Section.

## PART 2 PRODUCTS

### 2.1 MATERIALS

Comply with applicable materials described in the current DOTA "Construction Activities BMP Field Manual" and Section 3 and 4 of the current City and County of Honolulu "Storm Water Best Management Practice Manual." Refer to FAA Advisory Circulars and DOTA District, including Wildlife Hazard Management Plan, for additional guidance and conditions.

In addition, materials shall comply with the following:

- (A) Grass. The FAA and USDA recommend the following grass species when requiring grass: "No-Mow" bermudagrass ("Green Velvet") (*Cynodon dactylon*) or Seashore paspalum (*Paspalum vaginatum*). These species both possess higher than average drought resistance, saline soil tolerances, and, most importantly, do not produce seed heads attractive to the majority of hazardous avian species. It is recommended that stolons, sprigs, or plugs be used to avoid providing hazardous species with a readily available food source. The use of seeds shall not be allowed.

Alternative grass species shall only be applied with the approval of the DOTA Environmental Section. This includes, but not limited to, sodding, cuttings, and planting. Grass shall be a quick-growing species. Grass shall be suitable to the area and provide a temporary cover that will not compete later with permanent cover. The grass label or tag shall be provided to the DOTA Environmental Section.

Irrigation of these grass shall be done during the hours of darkness to avoid providing another hazardous wildlife attractant.

- (B) Fertilizer and Soil Conditioners. Fertilizer and soil conditioners shall conform to Hawaii Standard Specifications for Road and Bridge Construction 2005 or latest edition, Subsection 619.02(H)(1) – Commercial Fertilizer. Fertilizers shall not be applied during inclement weather or rain events.

The use of alternative types of fertilizer and soil conditioners shall be subject to the approval of the DOTA Environmental Section.

- (C) Hydro-mulching. Hydro-mulching used as a temporary stabilization measure shall consist of specially processed fiber which shall form a homogeneous slurry after addition and agitation in hydro-mulch applicator equipment.
1. Mulches shall be recycled materials including bagasse, hay, straw, wood cellulose bark, wood chips, or other material acceptable to the DOTA Environmental Section. Mulches shall be clean and free of noxious weeds and deleterious materials.
  2. Potable water shall meet the requirements of Hawaii Standard Specifications for Road and Bridge Construction 2005 or latest edition, Subsection 712.01 – Water. Submit alternate sources of irrigation water to the Engineer for acceptance by the DOTA Environmental Section if deviating from 712.01 – Water.
  3. Soil and Mulch Tackifier shall meet the requirements and installation in accordance with portions of Hawaii Standard Specifications for Road and Bridge Construction 2005 or latest edition, Section 641 – Hydro-Mulch Seeding, including 641.02(D) – Soil and Mulch Tackifier. The use of seeds in the hydro-mulch mixtures shall not be allowed.

Alternative materials or methods to control, prevent, remove, and dispose pollution are allowable if acceptable to the DOTA Environmental Section.

### PART 3 EXECUTION

#### 3.1 PRECONSTRUCTION REQUIREMENTS

- (A) Water Pollution, Dust, and Erosion Control Meeting. Schedule a water pollution, dust, and erosion control meeting with the Engineer after the Site-Specific BMP Plan is submitted to the Engineer and accepted in writing by the DOTA Environmental Section. The meeting shall be scheduled a minimum of 14 calendar days prior to the Start Work Date. At a minimum, the meeting shall be attended by the Contractor, applicable subcontractors, Engineer, DOTA Environmental Section and/or any authorized representatives of the designated attendees. The meeting will discuss the sequence of work, and plans and proposals for water pollution, dust, and erosion controls.

(B) Water Pollution, Dust, and Erosion Control Submittals.

Submit a Site-Specific BMP Plan within 30 calendar days of Contract Execution to the Engineer for acceptance by the DOTA Environmental Section. Submission of the complete and acceptable Site-Specific BMP Plan is the sole responsibility of the Contractor, and additional contract time will not be issued for delays due to incompleteness.

Include the following:

- 1 Written description of activities to minimize water pollution and soil erosion into drainage systems, sewer systems, and State waters. Include proposed means, methods, techniques, and procedures to be used for environmental control. BMP shall include, but not limited to, the following:
  - a. An identification of potential pollutants and their sources.
  - b. A list of all materials and heavy equipment to be used during construction.
  - c. Descriptions of the methods and devices used to minimize the discharge of pollutants into drainage systems, sewer system, and State waters.
  - d. Details of the procedures used for the maintenance and subsequent removal of any erosion or siltation control devices.
  - e. Methods of removing and disposing hazardous wastes encountered or generated during construction.
  - f. Methods of removing and disposing concrete and asphalt pavement cutting slurry, concrete curing water, and hydro-demolition water.
  - g. Spill Control and Prevention, and Emergency Spill Response Plan.
  - h. Fugitive dust control, including dust from earth-disturbing, hauling, grinding, sweeping, or brooming off operations, or combination thereof.
  - i. Methods of storing and handling of oils, paints, and other products used for the project.
  - j. Material storage and handling areas, and other staging areas, including storage of reinforcing steel and building material.
  - k. Concrete truck washouts.

- l. Concrete waste and asphalt concrete waste control.
  - m. Fueling and maintenance of vehicles and other equipment.
  - n. Tracking of sediment offsite from project entries and exits.
  - o. Litter management. Prevention of Foreign Object Debris (FOD) is essential.
  - p. Sanitary/Septic Waste Management and Facilities.
  - q. Stockpiles of Aggregates, Soils, Asphalt Concrete Material, Concrete Waste, and Asphalt Concrete Waste.
  - r. Methods of Handling and Removal of Contaminated Soils and Groundwater encountered or generated during construction.
  - s. Methods and Procedures for Dewatering.
  - t. Methods and Procedures for Hydro-Testing.
  - u. Methods and Practices for proper Housekeeping, including excessive sawdust; concrete spill prevention and removal; and collection and removal of building materials waste, such as tie wires, reinforcing steel, and lumber.
  - v. Other factors that may cause water pollution, dust, and erosion control.
- 2 Plans indicating location of water pollution, dust and erosion control devices; plans and details of BMP measures and devices to be installed or utilized; identify areas of soil disturbance in cut and fill; indicate areas used for construction staging and storage, including items (1) through (22) above, storage of aggregate (indicate type of aggregate), asphalt cold mix, soil or solid waste, equipment and vehicle parking, and areas where vegetative practices are to be implemented. Indicate intended drainage pattern on plans. Include flow arrows. Include separate drawing for each phase of construction that alters drainage patterns.
- 3 Dates when BMP measures will be installed and removed.
- 4 Name(s) of specific individual(s) designated responsible for the Contractor's Construction Site Runoff Control Program. Include cellular and business telephone numbers, fax numbers, and e-mail addresses. These individuals shall be available 24 hours a day, 7 days a week.

- 5 Description of fill material to be used.
- 6 For projects with an NGPC or NPDES Permit for Construction Activities, submit information to address all sections in the Storm Water Pollution Prevention Plan (SWPPP), as described in HAR Chapter 11-55, Appendix C, Section 7.
- 7 For projects with an NGPC or NPDES Permit, submit information required for compliance with the conditions of the Notice of General Permit Coverage (NGPC)/NPDES Permit.
- 8 Date and sign the Site-Specific BMP Plan.

Modify, as necessary, and resubmit amended Site-Specific BMP plans and construction schedules to the Engineer for acceptance by DOTA Environmental Section. Modify the Site-Specific BMP Plan to address, but not limited to, the following.

1. To correct conditions that develop during construction which were unforeseen during the design and pre-construction stages.
2. Changes to the Contractor's Means and Method of Construction.
3. Omitted conditions that should have been allowed for in the accepted Site-Specific BMP Plan.
4. A Site-Specific BMP measure that replaces an accepted Site-Specific BMP measure that was not satisfactorily performing.
5. Revised dates of installation and/or removal of Site-Specific BMP measures.

The modifications shall be submitted to the Engineer and accepted in writing by DOTA Environmental Section before implementing the revised Site-Specific BMPs in the field. Amendments to the Site-Specific BMP Plan shall be included with the original Site-Specific BMP Plan.

A copy of the accepted original Site-Specific BMP Plan and all accepted amended Site-Specific BMP Plans, with the signed certification by the authorized representative listed in the NGPC or NPDES Permit, shall be kept on site or at an accessible location so that it can be made available at the time of an on-site inspection, or upon request by the Engineer, DOTA Environmental Section, DOTA's Third Party Inspector, and/or DOH/EPA Representative.

- (C) Discharges of Stormwater Associated with Construction Activities. If the project scope consists of ground disturbing activities and the total work area, including all construction support activity areas (i.e. storage and/or staging areas), is one acre or more, an NPDES Permit authorizing Discharges of Storm Water Associated with Construction Activity (CWB-NOI Form C) or Individual Permit authorizing stormwater discharges associated with construction activity is required from the Department of Health Clean Water Branch (DOH-CWB).

Do not begin construction activities until all required conditions of the permit are met and submittals detailed in Subsection 01561.3.1(B) – Water Pollution, Dust, and Erosion Control Submittals are completed, submitted to the Engineer and accepted in writing by the DOTA Environmental Section.

- (D) Discharges Associated with Hydrotesting Activities. If hydrotesting activities require effluent discharge into State waters or drainage systems, an NPDES Hydrotesting Waters Permit (CWB-NOI Form F) or Individual Permit authorizing discharges associated with hydrotesting is required from the DOH-CWB.

Do not begin hydrotesting activities until the DOH-CWB has issued an Individual NPDES Permit or Notice of General Permit Coverage (NGPC). Conduct Hydrotesting operations in accordance with the conditions of the permit or NGPC.

- (E) Discharges Associated with Dewatering Activities. If dewatering activities require effluent discharge into State waters or drainage systems, an NPDES Dewatering Permit (CWB-NOI Form G) or Individual Permit authorizing discharges associated with dewatering is required from the DOH-CWB.

Do not begin dewatering activities until the DOH-CWB has issued an Individual NPDES Permit or Notice of General Permit Coverage (NGPC). Conduct dewatering operations in accordance with the conditions of the permit or NGPC.

- (F) Solid Waste Disclosure. Submit the Solid Waste Disclosure Form for Construction Sites, if applicable, to the Engineer within 30 calendar days of Contract Execution or upon the discovery of the solid waste. Provide a copy of all the disposal receipts from the facility permitted by the Department of Health to receive solid waste to the Engineer. This should also include documentation from any intermediary facility where solid waste is handled or processed.

- (G) Construction BMP Training. The Contractor's representative(s), identified in Section 01561.3.1(B)(4), responsible for the Contractor's Construction Site Runoff Control Program, site managers, and appropriate subcontractors' personnel shall be properly trained on environmental compliance by attending a designated DOTA training seminar (e.g. HDOT's Protect Our Water Conference) or viewing the DOTA construction and post-construction training available at:

<http://hidot.hawaii.gov/airports/doing-business/engineering/environmental/construction-site-runoff-control-program>

Submit completed Training Roster and Construction Training Quizzes to the DOTA Environmental Section (fax: 808-838-8017 or email to [dot.air.environmental@hawaii.gov](mailto:dot.air.environmental@hawaii.gov)) prior to the start of construction activities.

Individual workers must be trained on their site-specific BMPs by the Contractor's representative(s) and managers who are knowledgeable in the proper manufacturer's installation, maintenance, and repair of the BMP product, or the manufacturer's authorized instructor. The Contractor shall keep training logs updated and readily available.

- (H) Health and Safety Plan. A site-specific Health and Safety Plan for excavation work conducted in the known or suspected area of contamination shall be prepared and submitted at least 15 calendar days prior to initiating any excavation work. The Plan shall be applicable to Federal and State regulations.

The Contractor shall retain and pay for the services of a Certified Industrial Hygienist (CIH), certified by the American Board of Industrial Hygiene, to certify training, and review and approve the Health and Safety Plan, excavation procedures, including the determination of the need for personal protective equipment.

The Health and Safety Plan shall describe methods, techniques, and phases for handling the contaminated soil and groundwater, if present, including:

- 1 A sequence of operations.
- 2 Method of excavation, transporting, and disposal.
- 3 Soil Stockpiling and Groundwater Storage procedures.
- 4 Proposed equipment.
- 5 Provisions to ensure that chemical and petroleum constituent concentrations, both airborne and in the soil, are below the Department of Health Environmental Action Level (EAL), Permissible Exposure Limit (PEL) and below the Lower Explosive Limit (LEL). Provide soil testing, air monitoring, personnel monitoring, and air sampling to ensure worker safety as determined by CIH. If airborne concentrations exceed the PEL or the LEL at the control area boundary, then, work must stop immediately and the Engineer and DOTA Environmental Section notified.

### 3.2 CONSTRUCTION REQUIREMENTS

Do not begin work until submittals detailed in Subsection 01561.3.1(B) – Water Pollution, Dust, and Erosion Control Submittals are completed, submitted to the Engineer and accepted in writing by the DOTA Environmental Section, and required conditions of the NPDES Permit and other applicable permits are met.

Do not expose or disturb surface area of earth material, or initiate any ground-disturbing activities (including clearing and grubbing) until BMPs are installed, functional and accepted in writing by DOTA Environmental Section and/or their designated authorized representative. Only the soil, to the extent that is required to install the BMP measures and devices, shall be disturbed and minimized to the extent possible.

Install, maintain, monitor, repair and replace BMPs, such as for water pollution, dust, and erosion control; installation, monitoring, and operation of hydrotesting activities; removal and disposal of hazardous waste indicated on plans, concrete cutting slurry, concrete curing water; or hydro-demolition water. Address all comments received from the Engineer, DOTA Environmental Section and/or DOTA's Third-party inspector.

Coordinate temporary control provisions with permanent control features throughout the construction and post-construction period.

Protect temporarily or permanently disturbed soil surface from rainfall impact, runoff, and wind before the end of each work day. Coordinate and schedule the work to the maximum extent possible to minimize the amount of exposed or disturbed surface area of earth material.

Immediately *initiate* stabilizing exposed soil areas upon completion of earth disturbing activities for areas permanently or temporarily ceased on any portion of the site. Earth-disturbing activities have permanently ceased when clearing and excavation within any area of the construction site that will not include permanent structures has been completed. Earth-disturbing activities have temporarily ceased when clearing, grading, or excavation within any area of the site will not resume for a period of 14 or more calendar days, but such activities will resume in the future. The term "immediately" is used in this section to define the deadline for *initiating* stabilization measures. "Immediately" means as soon as practicable, but no later than the end of the next work day, following the day when the earth-disturbing activities have temporarily or permanently ceased.

Any of the following types of activities constitutes *initiation of stabilization*:

1. Prepping the soil for vegetative or non-vegetative stabilization;
2. Applying mulch or other non-vegetative product to the exposed area;
3. Planting the exposed area;

4. Starting any of the activities in items (1) – (3) above on a portion of the area to be stabilized, but not on the entire area; and
5. Finalizing arrangements to have stabilization product fully installed in compliance with the deadline for completing initial stabilization activities.

After the initiation of stabilization, stabilization activities shall be completed by the following deadline.

1. For projects with an NGPC or NPDES Permit for Construction activities:
  - (a) For construction areas discharging into waters not impaired for nutrients or sediments, complete stabilization within 14 calendar days after the temporary or permanent cessation of earth-disturbing activities.
  - (b) For construction areas discharging into nutrient or sediment impaired waters, complete stabilization within 7 calendar days after the temporary or permanent cessation of earth-disturbing activities.
2. For projects without an NGPC or NPDES Permit for Construction activities, complete stabilization within 14 calendar days after the temporary or permanent cessation of earth-disturbing activities.

Any of the following types of activities constitutes completion of stabilization activities:

1. For vegetative stabilization, all activities necessary to initially plant the area to be stabilized; and/or
2. For non-vegetative stabilization, the installation or application of all such non-vegetative measures.

If the Contractor is using vegetative cover for temporary or permanent stabilization and is unable to meet the deadlines above due to circumstances beyond the Contractor's control, the Contractor shall notify and provide documentation of the circumstances to the Engineer for acceptance by DOTA Environmental Section. The Contractor shall include in their documentation the schedule that the Contractor will follow for initiating and completing stabilization. If agreed to by DOTA Environmental Section, the Contractor may, instead, comply with the following stabilization deadlines:

1. Immediately initiate, and complete within the timeframe shown above, the installation of temporary non-vegetative stabilization measures to prevent erosion;
2. Complete all soil conditioning, planting, watering or irrigation installation, mulching, and other required activities related to the planting and initial establishment of vegetation as soon as conditions or circumstances allow it on the site.

Follow the applicable requirements of the contract documents including Hawaii Standard Specifications for Road and Bridge Construction 2005 or latest edition, Section 619 and Section 641, as amended.

Where necessary to prevent erosion on the planted area, immediately install non-vegetative erosion controls that provide cover (e.g., mulch, rolled erosion control products) to the area while vegetation is becoming established.

Protect exposed or disturbed surface area with mulches or hydro-mulch with no seeds. Spray mulches at a rate of 2,000 pounds per acre. Add tackifier to mix at a rate of 85 pounds per acre. For hydro-mulch, use the ingredients and rates required for mulches. Apply fertilizer, if applicable, per the manufacturer's recommendations. Mulches, hydro mulch, and/or fertilizers shall not be applied during inclement weather or rain events. Submit recommendations from a licensed Landscape Architect when deviating from the application rates above or manufacturer's recommendations.

Install velocity dissipation measures when exposing erodible surfaces greater than 15 feet in height.

BMP measures shall be in place and operational at the end of each work day or as required by Section 01561.3.1(B).

Install and maintain stabilized construction entrances, including any wheel washes, to minimize tracking of dirt and mud onto roadways, sidewalks, and other paved areas. Restrict traffic to stabilized construction entrance areas only. Clean dirt, mud, or other material tracked onto the road, sidewalk, or other paved area by the end of the same day in which the track-out occurs. If tracking is excessive or sediment is being transported farther along the pavement or sidewalk by other vehicles traveling outside of the construction site, then, conduct cleaning and sweeping immediately. Modify stabilized construction entrances, as needed, to prevent mud from being tracked onto road. Stabilize entire access roads if necessary.

Maintain all excavations, embankments, haul roads, permanent access roads, plant sites, waste disposal areas, borrow areas, and all other work areas within the project limits free from dust which would cause a hazard to the work, airport operations, operations of other contractors, or to persons or property. Chemicals may be used as soil stabilizers for erosion and dust control. Submit the manufacturer's product data sheets of the chemicals to the Engineer for acceptance by the DOTA Environmental Section. Oil treating shall not be used. When using water for dust control, only potable water, that conform to Hawaii Standard Specifications for Road and Bridge Construction 2005 or latest edition, Subsection 712.01 – Water, shall be used. Dust screens and fabrics are not allowed on, or inhibit the view of, the TSA and AOA Security Fences.

Cover exposed surface of materials completely with tarpaulin or a similar device when transporting aggregate, soil, excavated material, or other materials that may be a source of fugitive dust.

Provide temporary slope drains of rigid or flexible conduits to carry runoff from cuts and embankments. Provide portable flume at the entrance. Shorten or extend temporary slope drains to ensure proper function.

Protect ditches, channels, and other drainageways leading away from cuts and fills at all times by either:

1. Hydro-mulching the lower region of embankments in the immediate area.
2. Installing check dams and siltation control devices.
3. Other methods acceptable to the DOTA Environmental Section.

Provide for controlled discharge of waters impounded, directed, or controlled by project activities or erosion control measures.

Cleanup and remove any pollutant that is attributed to the Contractor. Deposit of solid waste or the discharge of liquid waste, such as fuels, lubricants, bituminous waste, untreated sewage and other pollutants which may contaminate the body of ground water shall not be permitted. Care shall be taken to ensure that no petroleum products, bituminous materials, or other deleterious substances, including debris, are allowed to fall, flow, leach, or otherwise enter the sewage systems or storm drains.

Burning of matter or waste material on Airport property shall not be permitted.

The use of hazardous materials is prohibited without the approval of the Engineer. Any corrective actions to remove and replace the hazardous material and contaminated work shall be at the sole expense of the Contractor. Hazardous materials shall be properly stored and handled.

### 3.3 INSPECTIONS

For all projects with earth-disturbing activities, including construction support activity areas, the following inspections shall be conducted:

- (A) Initial Inspection of BMPs. Prior to the start of construction activities, the DOTA Environmental Section, or their designated authorized representative, will conduct an initial site inspection of the BMPs.

The Contractor shall submit their request for this inspection in writing to the Engineer. The inspection is subject to the availability of the DOTA Environmental Section or their designated authorized representative.

Prior to this inspection, only the soil, to the extent that is required to install the BMP measures and devices, shall be disturbed. During the inspection, the inspector will note any deficiencies in the BMP measures and devices, including identifying any

site conditions that have the potential to result in the discharge of pollutants. The Contractor is responsible for the correction of the deficiencies. Corrective Action shall be documented and submitted to the Engineer for acceptance by the DOTA Environmental Section and/or their designated authorized representative. The deficiencies must be corrected and accepted before construction activities are allowed to commence.

Initial Inspections shall be conducted separately for each new construction phase, new work areas, and additional construction support areas that occur during the construction period.

- (B) Contractor's Inspection of BMPs. Commencing immediately after the Initial BMP Inspection and until the acceptance of the Final BMP Inspection, the Contractor shall conduct inspections of the sites to ensure that BMPs are effective and activities do not have the potential of causing a polluted discharge.

The Contractor's Inspections shall be conducted at the following intervals:

- 1 Weekly.
- 2 Within 24 hours of any rainfall of 0.25 inch or greater which occurs in a 24-hour period.

The Contractor shall use on-line rainfall measurements data sources and providers. Rainfall measurements shall be taken from the same airport as the location of the project or within one (1) mile distance from the disturbed areas. Submit the identity of the provider, with the location of their measuring device, to the Engineer for approval by DOTA Environmental Section.

In lieu of using any on-line rainfall provider or if there are no measuring device of an on-line provider on the airport or within one (1) mile from the disturbed area, the Contractor shall furnish and install a rain gauge in a secure location prior to field work including installation of site-specific BMPs. Provide a rain gauge with a tolerance of at least 0.05 inches of rainfall. Install the rain gauge on the project site in an area that will not deter rainfall from entering the gauge opening. Do not install in a location where rain water may splash into the rain gauge. The rain gauge installation shall be stable and plumbed. Maintain rain gauge and replace any rain gauge that is stolen, does not function properly or accurately, is worn out, or needs to be relocated. Do not begin field work until the rain gauge is installed and Site-Specific BMPs are in place. Rain gauge data logs shall be readily available.

Submit rain gage data logs weekly with the Contractor's BMP Inspection Report to the Engineer for acceptance by the DOTA Environmental Section.

- 3 When existing erosion control measures are damaged or not operating properly as required by Site-Specific BMP.

Prepare a written report of the inspection and submit a copy of the report within 24-hours to the Engineer for acceptance by the DOTA Environmental Section. The report must include any deficiencies of the Site-Specific BMPs observed and the correction of these deficiencies. Corrective actions can be documented in a separate report and submitted upon completion of the corrective actions. Submit the report(s) to the Engineer for acceptance by DOTA Environmental Section.

The initiation of the work to repair or correct the deficiency shall begin immediately. However, except for those deficiencies that pose an immediate threat for the discharge of pollutants to the drainage system, surface waters, or receiving water, if the deficiency is identified at a time in the day in which it is too late to initiate the work, the initiation of the work shall begin on the following day.

After the initiation of the work to repair or correct the deficiency, the work shall be completed as follows:

1. If the deficiency poses an immediate threat for the discharge of pollutants to the drainage system, surface waters, or receiving waters, the work to fix the deficiency shall be completed by the close of the same day of discovery of the deficiency. Examples of these deficiencies included, but not limited to, illicit discharge, absence of perimeter controls in an area with evidence of sediment transporting off-site, and spills near a drain or waterway that have not been cleaned.
2. If the deficiency poses a significant threat for the discharge of pollutants to the drainage system, surface waters, or receiving waters, the work to fix the deficiency shall be completed by five (5) calendar days or before the next forecasted rain event, whichever is sooner. Examples of these deficiencies include, but not limited to, perimeter controls that are not functional or require maintenance, drain inlet protections that are not functional or require maintenance, installation of a new pollution prevention control, and deficiencies requiring significant repair for the correction of the deficiency.
3. If the deficiency does not pose a threat for the discharge of pollutants to the drainage system, surface waters, or receiving waters, but are not in strict conformance with the SWPPP, SSBMP Plan, or DOTA's Construction Activities BMP Field Manual, the work to correct the deficiency shall be completed by ten (10) calendar days or within the time specified by the

Engineer, whichever is sooner. These deficiencies include all deficiencies except those deficiencies included in (1) and (2), above.

4. If it is infeasible to complete the correction of the deficiency or installation of a new pollution prevention control within the respective timeframe above, notify the Engineer who will consult with DOTA Environmental Section. Document why it is infeasible to complete the work within the required timeframe. Complete the work as soon as practicable and as agreed to by both the Engineer and DOTA Environmental Section.

Retain copies of these inspection reports on-site or at an accessible location for the duration of the project so that they can be made available at the time of an on-site inspection, or upon request by the Engineer, DOTA Environmental Section, DOTA's Third Party Inspector, and/or DOH/EPA Representative. Present these inspection reports to the DOTA's Third-Party Inspectors at the time of their inspection for review.

- (C) Final Inspection / Post-construction BMP Initial Inspection. The DOTA Environmental Section, or their designated authorized representative, shall conduct a Final Inspection / Post-Construction BMP initial inspection when the Contractor has completed construction, including installing permanent BMPs and stabilizing exposed soil.

The Contractor shall submit the request for this inspection in writing to the Engineer. The inspection is subject to the availability of the DOTA Environmental Section or their designated authorized representative.

All deficiencies noted must be addressed before the Contractor can remove temporary BMPs and close the site. The Contractor is responsible for correction of the deficiencies. Corrective Action shall be documented and submitted to the Engineer for acceptance by the DOTA Environmental Section. Any deficiencies noted during the final inspection must be corrected before the State will issue the project final acceptance and make final payment.

Partial Final Inspection of construction phases or partial areas of the project shall be conducted during the construction of the project for areas that are to be transferred for DOTA's use.

- (D) Routine Inspections Conducted by DOTA. The Contractor's designated representative specified in Subsection 01561.3.1(B)(4) shall address any Site-Specific BMP deficiencies brought up by the Engineer or their authorized representative (i.e. Quality Control Engineer, Project Inspector, etc.) taking all reasonable measures to minimize or prevent discharge of pollutants until a permanent solution is installed and made operational.

The initiation of the work to repair and correction of the deficiency shall be completed within the same timelines as required in Subsection 01561.3.3(B).

(E) DOTA's SWMPP Inspections. *For Projects located at the Daniel K. Inouye International Airport (HNL) or the Kahului Airport (OGG)* that have a NGPC or NPDES Permit, or disturb one acre or more, including the construction support activity areas, the following additional inspections shall be conducted:

1 Third-Party Inspections. The DOTA Environmental Section's Third-Party inspector will conduct routine inspections. Third-party inspections shall be conducted monthly. The frequency of the inspections may increase if deficiencies are identified as determined by the inspector. Deficiencies must be corrected within the timeline defined in DOTA's SWMPP, Section C, Construction Site Runoff Control Program, which can be downloaded from the website:

<http://hidot.hawaii.gov/airports/doingbusiness/engineering/environmental/construction-site-runoff-control-program/>

The Contractor shall be responsible for the correction of ALL deficiencies identified during any of the above inspections. Corrective Action shall be documented and submitted to the Engineer for acceptance by the DOTA Environmental Section or their designated authorized representative.

If the Contractor fails to satisfactorily address Site-Specific BMP deficiencies, the DOTA reserves the right to employ outside assistance or use the State's own labor forces to provide necessary corrective measures. The Contractor will be fully responsible for all cost and time. The State will charge the Contractor such incurred costs plus any associated project engineering costs and will make appropriate deductions from the Contractor's monthly progress payment.

Failure to apply or maintain Site-Specific BMP measures may result in the assessment of liquidated damages (Appendix B). Depending on the severity of the deficiencies, additional enforcement actions, such as, suspension of work and/or termination of the contract (with the Contractor's Surety being fully responsible for all additional costs incurred by the State) can be conducted and assessed against the Contractor.

For all citations or fines received by the DOTA for non-compliance, including non-compliance with NGPC/NPDES Permit conditions, the Contractor shall reimburse the State within 30 calendar days for the full amount of outstanding cost that the State has incurred, or the State shall deduct all incurred costs from the Contractor's monthly progress payments.

The Contractor shall be responsible for all citations, fines and penalties levied by DOH or EPA against the State due to the Contractor's failure to satisfactorily address Site-Specific

BMP deficiencies and/or any Contractor's illicit discharges. The State will make the appropriate deductions from the Contractor's monthly progress payment.

#### PART 4 MEASUREMENT AND PAYMENT

##### 3.1 BASIS OF MEASUREMENT AND PAYMENT

The work specified in this Section will be paid for at the contract lump sum price. Payment shall be full compensation for work prescribed in this Section and contract documents, including but not limited to, all labor, materials, tools, equipment, and all incidentals necessary to install, maintain, monitor, repair, replace, modify, and remove Site-Specific BMP measures.

<u>Item No.</u>	<u>Item</u>	<u>Unit</u>
01561.1	Construction Site Runoff Control Program	Lump Sum

Partial payments shall be paid in the Monthly Progress Payment as follows:

1. 20% of the line item price shall be paid upon DOTA Environmental Section's acceptance in writing of the Site-Specific BMP Plan and the satisfactory completion of the Initial Inspection of BMPs defined in Section 01561.3.3(A), above.
2. 60% of the line item price shall be paid in equal monthly payments over the duration of the contract. Failure to satisfactorily apply, maintain, or modify BMP measures and devices, and/or submittals shall result in the withholding of monthly progress payments for this line item.

**For projects located at the Daniel K. Inouye International Airport (HNL) or the Kahului Airport (OGG) that have a NGPC or NPDES Permit, or disturb one (1) acre or more, including construction support activity areas, payments shall be made only after the DOTA's Third-Party Inspection defined in Section 01561.3.3(E), above, have been satisfactorily completed and accepted by the DOTA Environmental Section. Any deficiencies classified as Major or above will result in the withholding of monthly progress payments for this line item.**

3. The remaining 20% of the line item price shall be paid after all BMP measures have been satisfactorily removed.

Payment will be made only after the satisfactory completion of the Final Inspection / Post-Construction BMP Initial Inspection defined in Section 01561.3.3(C), above, and acceptance of the Post-Construction BMPs by the DOTA Environmental Section.

Liquidated Damages, up to \$25,000 per day (Appendix B), shall be assessed for each non-compliance of the BMP requirements described in this Section. The Contractor shall not be entitled to recover any Liquidated Damages assessed, even after the deficiencies have been corrected.

## Appendix A

The current DOTA's Construction Activities Best Management Practices (BMP) Field Manual can be found on DOTA's Environmental Website at

<https://hidot.hawaii.gov/airports/doing-business/engineering/environmental/construction-site-runoff-control-program/>

The manual is periodically updated and should be downloaded via the website to ensure that the latest version is applied. The manual identifies potential pollutant sources and BMPs that should be used to mitigate pollutants.

Additional information and requirements for stormwater programs at all airports can also be found at the above website, including additional requirements for Daniel K. Inouye International Airport (HNL) and Kahului Airport (OGG).

**Appendix B Liquidated Damages Schedule for Non-Compliances.**

Non-Compliance	Amount
Failure to submit a Notice of Intent or otherwise obtain a permit for Staging and/or Storage Area beyond the project limits.	\$1,000 per calendar day per violation.
Failure to comply with the conditions specified in the Notice of General Permit Coverage (NGPC) or Individual NPDES Permit, or any other applicable permit.	\$1,000 per calendar day per violation.
Failure to have the accepted SSBMP Plan and Amendments or the accepted SWPPP and Amendments available at a project construction site.	\$1,000 per calendar day per violation.
Failure to install a BMP specified by the SSBMP Plan or SWPPP, or permit.	\$2,000 per calendar day per violation.
Failure to properly install or maintain appropriate Site-Specific BMPs in accordance with applicable plans, permits, and guidance documents.	\$2,000 per calendar day per violation.
<p>Failure to have an accepted Amendment to the SSBMP Plan or an accepted Amendment to the SWPPP prior to implementation of the proposed BMPs.</p> <p>Note: Advance review and acceptance can be provided via email which will satisfy this non-compliance. However, the written Amendment must still be formally submitted for certification and signature by the authorized representative identified in the NGPC or NPDES Permit.</p>	\$2,000 per calendar day per violation.
Failure to conduct required inspections.	<p>\$1,000 for each of the first ten violations,</p> <p>\$2,500 for each of the next ten violations,</p> <p>\$5,000 for each subsequent violation.</p>
Failure to submit required reports such as BMP inspection reports, rain gauge data logs, etc.	<p>\$500 per calendar day for the first ten days of each violation,</p> <p>\$1,000 per calendar day for the next ten days of each violation,</p> <p>\$2,500 per calendar day for each subsequent day of violation.</p>

Non-Compliance	Amount
Any "major" or "critical" non-compliance violation with the applicable plans, permits, and guidance documents.	Up to \$25,000 per calendar day per violation.
Any violation resulting in a polluted discharge.	Up to \$25,000 per calendar day per violation.

Note: Liquidated Damages shown in the Table shall be assessed at the discretion of the DOTA.

#### Assessment of Liquidated Damages for Non-Compliance:

The Contractor may be assessed liquidated damages by issuance of an Enforcement Letter. The Enforcement Letter shall indicate the amount of liquidated damages that are assessed for the non-compliances which shall be deducted from the Contractor's next progress payment. The Enforcement Letter will be sent electronically via e-mail and a hard copy to the Contractor's designated representative(s), identified in Section 01561.3.01(B)(4), responsible for the Contractor's Construction Site Runoff Control Program. An Enforcement Letter may be issued with or without a previous Verbal Notification, Warning Letter, or Notice of Apparent Violation (NAV).

Liquidated Damages may be assessed for the following:

- Non-compliances listed in the Table, herein, included in Appendix B.
- Non-compliances have not been corrected in the timeframes noted.
- Corrective actions are not completed after a Verbal Notification, Warning Letter, or Notice of Apparent Violation is issued.
- Contractors are non-responsive to DOTA's directives.
- Repeated non-compliance.
- A polluted discharge has occurred.

The number of days used for the liquidated damages calculations shall start on the day that the non-compliance was required to be corrected and shall end on the day that the non-compliance is corrected and accepted. If DOTA's personnel are not able to go out in the field to verify that the BMP deficiencies are corrected in the timeframe specified, the Contractor can send photographs showing the corrected deficiency via e-mail to the Engineer and DOTA Environmental Section along with documentation on how the deficiency was corrected. The Engineer and DOTA Environmental Section may visit the site to verify the corrective actions are acceptable. If the

corrective actions are acceptable, then the clock stops on the day that the documentation was received.

END OF SECTION

REPLACE IIT CONFERENCE CENTER ROOM DIVIDERS  
DANIEL K. INOUE INTERNATIONAL AIRPORT  
STATE PROJECT NO. CO1342-43

CONSTRUCTION SITE RUNOFF  
CONTROL PROGRAM  
01561-22  
03/01/20

## SECTION 01562 – MANAGEMENT OF CONTAMINATED MEDIAS

### PART 1 – GENERAL

#### 1.1 RELATED DOCUMENTS

The General Provisions, Special Provisions, and General Requirements of the Specifications apply to the work specified in this section.

#### 1.2 DESCRIPTION AND SCOPE OF WORK

- A. This Section describes procedures for the management of contaminated media (soil, groundwater, and soil vapor) that may be disturbed during excavation activities associated with this project.
- B. The Contractor shall supply all labor, materials, and equipment necessary for the removal, temporary storage, testing, handling, soil backfilling and management of contaminated media to carry out the work in accordance with these specifications, and all applicable Federal, State, and local regulations and latest amendments.
- C. The Contractor shall examine the State of Hawaii, Department of Transportation, Airports Division (DOTA) Programmatic Environmental Hazard Evaluation and Environmental Hazard Management Plan (DOTA EHE-EHMP) and, if included as part of these specifications, the Environmental Site Assessment (ESA) Phase II, to understand the conditions that may affect work and performance. Should the Contractor deviate from the DOTA EHE-EHMP or ESA, the Contractor shall be responsible to prepare a DOH required Construction EHMP (C-EHMP) utilizing the C-EHMP Addendum Template or most recent version provided by DOH, also known as a Site-Specific EHMP. Any deviation will require approval by the State of Hawaii, Department of Health (HDOH) and DOTA Environmental Section (DOTA AIR-EE) prior to implementation, using the forms provided in Appendix B of the DOTA EHE-EHMP. The forms should detail deviations from standard practices in the text and explain how those deviations will be protective of human health and the environment. The forms should be submitted to HDOH and DOTA AIR-EE for review and approval if deviations are requested or if notifying of a release.
- D. It should be noted that the DOTA EHE-EHMP is for Contaminants of Potential Concern (COPCs) which include, but not limited to, the following:
- Petroleum Substances, e.g., TPH, TPH-g, TPH-d, TPH-o, BTEX, and PAHs.
  - Chlorinated Solvents, e.g., VOCs
  - Polychlorinated Biphenyls (PCBs)
  - Pesticides, e.g., chlordane
  - Heavy Metals, e.g., Arsenic, Barium, Cadmium, Total Chromium, Lead, Mercury, Selenium, and Silver.

In addition, free product (e.g., gasoline, diesel fuel, fuel oils, lubricating oils, benzene, toluene, xylenes) may be encountered in areas of previous petroleum releases.

Should the ESA Phase II identify contaminants other than those listed above or there

is a risk to human health and/or the environment (such as indoor air quality in an occupied building), the Contractor shall be responsible to revise, update, and finalize the C-EHMP Addendum. The Contractor shall coordinate with, as well as have their C-EHMP approved by HDOH prior to the start of any ground disturbing activities.

### 1.3 REFERENCES

- A. Programmatic Environmental Hazard Evaluation and Environmental Hazard Management Plan dated July 2019, or its latest edition.
- B. DOTA's Storm Water Management Program Plan (SWMPP) for the Daniel K. Inouye International Airport (HNL) and Kahului Airport (OGG), including DOTA's Construction Activities BMP Field Manual dated August 2019, or its latest edition.
- C. All work under this contract shall be performed in strict accordance with all applicable Federal, State, and local regulations, standards, and codes governing contaminated media.
- D. The most recent editions of any relevant regulations, standards, documents, or codes shall be in effect, including, but not limited to, the following. Where conflicts among the requirements or with these specifications exists, the most stringent requirements shall apply.
  - 1. 29 CFR 1910, "Occupational Safety and Health Standards".
  - 2. 29 CFR 1926, "Safety and Health Regulations for Construction".
  - 3. 40 CFR 50, "National Primary and Secondary Ambient Air Quality Standards A".
  - 4. 40 CFR 122, "EPA Administered Permit Program: The National Pollutant Discharge Elimination System".
  - 5. 40 CFR 261, "Identification and Listing of Hazardous Waste".
  - 6. 40 CFR 263, "Standards Applicable to Transporters of Hazardous Waste".
  - 7. 40 CFR 302, "Designation, Reportable Quantities, and Notification".
  - 8. 49 CFR 172, Subpart E, "Labeling".
  - 9. 49 CFR 172, Subpart F, "Placarding".
  - 10. The Hawaii Environmental Response Law (Hawaii Revised Statutes [HRS] Chapter 128D) and the State Contingency Plan (Hawaii Administrative Rules [HAR] Title 11, Chapters 451-1–451-24).
  - 11. The Hazard Evaluation and Emergency Response Office Technical Guidance Manual (TGM) for Implementation of the State Contingency Plan (Interim Final, June 21, 2009).
  - 12. Hawaii Hazardous Waste Laws and Regulations (HRS Chapter 342J, HAR Title 11, Chapters 260.1–279.1).

13. Hawaii Solid Waste Laws and Regulations (HRS Chapters 342H and I, HAR Title 11, Chapter 58.1).
14. Hawaii Underground Storage Tank Laws and Regulations (HRS Chapter 342L; HAR Title 11, Chapter 280.1).
15. Hawaii Water Quality Standards (HAR Title 11, Chapter 54).
16. Hawaii Ambient Air Quality Standards (HAR Title 11, Chapter 59).
17. Hawaii Occupational Safety and Health Standards (HAR Title 12, Subtitle 8).
18. Hawaii Department of Health, Office of Hazard Evaluation and Emergency Response. Screening for Environmental Hazards at Sites with Contaminated Soil and Groundwater. Website URL: <http://eha-web.doh.hawaii.gov/eha-cma/Leaders/HEER/EALs>. Fall 2011 (and updates).
19. Hawaii Department of Health, Office of Hazard Evaluation and Emergency Response. Guidance for Soil Stockpile Characterization and Evaluation of Imported and Exported Fill Material. Website URL: <http://eha-web.doh.hawaii.gov/eha-cma/Leaders/HEER/technical-guidance-and-fact-sheets>. October 8, 2017 (and updates).
20. Hawaii Department of Health, Office of Hazard Evaluation and Emergency Response. Construction EHMP Addendum Template, available from AIR-EE.
21. U.S. Environmental Protection Agency (EPA): Comprehensive Environmental Restoration, Compensation, and Liability Act, Section 107(1), 1980, exemption for cleanup of legally applied pesticide products.

## PART 2 – PRODUCTS

### 2.1 PERSONAL PROTECTIVE EQUIPMENT & SIGNAGE

- A. Provide workers with Personal Protective Equipment (PPE) according to the Contractor's PPE Assessment.
- B. Provide warning signs and labels to protect the workers and the public.

### 2.2 POLYETHYLENE SHEETING

Sheet plastic shall be new, and clear or black with at least 20-mil thickness. A 6-mil plastic sheet can be used to cover the stockpiles.

## PART 3 – EXECUTION

### 3.1 GENERAL WORK PROCEDURES

- A. Prior to beginning work, the Contractor, the Contractor's Qualified Environmental Professional, and DOTA Engineer or its representative shall discuss the approved

Work Plan, as described in Paragraph 3.2 below, including work procedures and safety precautions.

- B. Communicate any existing, potential, or new hazards to workers before a job begins or as necessary. The workers shall be aware of the need for proper safety procedures and be familiar with the Contractor's Work Plan.
- C. Boundaries shall be established at each area where soil excavation is to be performed. The area shall be clearly identified to prevent unauthorized entry. Establish a control area by completely enclosing/roping-off the area where contaminated soil excavation, removal, stockpiling and disposal operations will be performed.
- D. Provide physical boundaries around the control area by roping-off the area to ensure that airborne concentrations of COPC will not exceed permissible exposure limits outside the control area.
- E. Where applicable, caution signs shall be placed at the entrances to each work area, located such that approaching personnel may read the signs and take necessary precautions before entering the work area. No one will be permitted in the work area unless the person is provided with appropriate training and protective equipment.
- F. It should be noted that, in some cases, the contamination may not be identifiable through visual and/or olfactory observation (e.g., soil contaminated with metals, PCBs, pesticides, etc.) and contaminant-specific field screening techniques may need to be implemented.
- G. Measure, monitor, and record worker exposure to toxic materials or harmful agents as necessary.
- H. Follow Decontamination regulations and procedures as necessary.
- I. Soil excavation activities, grading, and any disturbance of impacted soil may cause a potential exposure to Contractor's employees and the general public due to fugitive dust. The routes of exposure of dusts are by inhalation, ingestion, and dermal contact. The Contractor shall use engineering controls such as water spraying and wind barriers to control fugitive dust.
- J. The Contractor shall test residual soils not used as backfill for COPC. Soils with concentrations above regulatory and/or unrestricted use environmental action levels shall be disposed of in accordance with regulatory requirements.
- K. Report construction activities in areas with contaminated soil or groundwater by completing the appropriate forms in the DOTA EHE-EHMP, Appendix B.3 Construction Activities Release Response Plan. Submit the forms to the HDOH Office of Hazard Evaluation and Emergency Response (HEER Office) and provide a copy of the forms to the DOTA Engineer and DOTA AIR-EE.

### 3.2 PRECONSTRUCTION REQUIREMENTS

- A. Submit the following a minimum of 30 calendar days prior to beginning any ground

disturbing activities, for approval by DOTA AIR-EE.

1. Contractor's Work Plan for Known or Suspected Areas of Contaminated Media:

- a. The Contractor shall submit their work plan which shall include, but not limited to, a Site-Specific Health and Safety Plan (HASp) or if needed, a C-EHMP. The work plan shall describe the procedures, engineering controls, and methods the Contractor will use during the excavation, temporary storage, handling, treatment, backfilling, and disposal of soil and/or water at the project site. The plan shall also include soil stockpiling and segregation, testing, contaminated soil and water quality testing, contaminated soil and water disposal procedures, backfilling procedures, personal protection requirements, work area isolation, construction barriers, wetting methods, decontamination procedures, and emergency procedures. The work plan shall be in accordance to all applicable Federal, State, and local regulations and latest amendments.

**For locations within the airport which DOTA has already established a Site-Specific EHMP from previous projects, the DOTA's Site-Specific EHMP, shall govern, where applicable.**

- b. The plan shall include the names of the Contractor's and their subcontractor's qualified personnel who will be supervising or managing the management of contaminated materials at the site. Include the personnel's phone number and qualifications.
- c. The plan shall include the name(s) of the Contractor's Qualified Environmental Professional, including their qualifications.
- d. Proposed schedule of work.
- e. A sketch identifying the location of temporary soil stockpiling and water storage devices, including pipes and appurtenances, if applicable.
- f. A map showing the location of the work and nearest medical facilities and hospitals.
- g. A copy of this Work Plan must be on the construction site and available at all times.
- h. The Work Plan shall be amended to reflect changes to the site or work conditions, as needed.

**B. QUALIFIED ENVIRONMENTAL PROFESSIONAL**

The Contractor shall employ a Qualified Environmental Professional who possesses five (5) years, minimum, experience providing environmental oversight for the management of contaminated media during construction activities. The Environmental Professional shall assist in the preparation of the Contractor's Work Plan by reviewing the work procedures, including the determination of the need for

PPE, and to provide environmental oversight during construction. The Environmental Professional shall be identified in the Work Plan, including a list of their environmental qualifications, for approval by DOTA AIR-EE.

### C. CONTRACTOR TRAINING

The Contractor and its subcontractors shall implement safe work places and practices by eliminating, mitigating, or protecting against existing or potential hazards to the workers who may be exposed to harmful, hazardous, and toxic materials and substances, including contaminated water and soil.

## 3.3 CONSTRUCTION REQUIREMENTS

### A. SOIL EXCAVATION AND STOCKPILING

1. Notify the HDOH Clean Water Branch (CWB) at least 90 calendar days prior to disturbing contaminated soil from known areas of contamination. Notify the HDOH HEER Office at least seven (7) calendar days prior to construction activities that could disturb known contaminated soil.
2. The HDOH HEER Office shall be immediately notified if contaminated soils are encountered. The disturbance of contaminated soil shall be performed in accordance with the Contractor's approved Work Plan, the DOTA EHE-EHMP, or a C- EHMP Addendum where applicable. HDOH HEER Office will determine whether additional sampling is required. Provide a location map with Global Positioning System (GPS) coordinates and approximate depth (bgs) at which the contaminated soils were encountered to the DOTA Engineer and DOTA AIR-EE.
3. During excavation and disturbance of impacted soil, all workers, supervisory personnel, subcontractors, and consultants must take precautionary measures as necessary to prevent exposure of the workers and the general public to chemicals of concern (COCs) by contaminated soil dust and inhalation of associated vapors.
4. The Contractor's Qualified Environmental Professional shall direct the segregation of the soil into three (3) separate soil piles: Pile No. 1 will consist of clean soil; Pile No. 2 will consist of soil excavated from areas found to be contaminated or suspected to be contaminated; and Pile No. 3 will consist of soil that is grossly contaminated. Contaminated soil stockpiles, suspected contaminated soil stockpiles, and grossly contaminated soil stockpiles shall be placed onto 20-mil plastic sheeting. Underlay edges of the plastic sheeting with bermed soil. Ensure that the height of the bermed soil will be sufficient to prevent stormwater runoff from breaching it. Place the excavated soil inside the bermed area on top of the plastic sheeting. Cover the stockpiles with 6-mil plastic sheeting in the bermed area to mitigate dust concerns caused by wind and prevent contact with rainwater and stormwater runoff. Secure the plastic cover with sufficient ballast and place sediment control devices along the entire toe of each stockpile.
5. Each stockpile shall not exceed 100 cubic yards and shall be located away from drainage features, surface waters, and stormwater drainage paths. Or, the soils

can be placed in watertight containers, such as 20-yard steel roll-off bins, drums, etc. These containers shall be covered.

6. The Contractor shall have representative soil samples taken from each stockpile (Pile No. 1, 2, and 3) and tested in accordance with HDOH guidelines, standards, and regulations, such that the soil sample report, prepared by the Contractor's Qualified Environmental Professional, can specifically state one of the following:
  - a. "The soil is not a regulated hazardous waste and is acceptable for disposal at a HDOH permitted facility."; or
  - b. "The soil is acceptable for unrestricted reuse."

Sampling and testing of the stockpiles shall be, at a minimum, in accordance to the latest edition of the HDOH's *Guidance for Soil Stockpile Characterization and Evaluation of Imported and Exported Fill Material*. The Contractor's Qualified Environmental Professional shall direct the soil sampling collection and testing methods in accordance with the most current guidelines. Stockpiles shall be tested using multi-increment (MI) sampling approaches. Appropriate decision unit (DU) volumes for larger stockpiles of soil should be discussed with the HDOH HEER Office on a case-by-case basis.

The Contractor shall also confirm, with the HDOH permitted facility, the facility's sampling requirements, as well as their standards for disposal.

7. Any liquid-phase oil or free product associated with the contaminated soil shall be drained prior to stockpiling. If feasible, the free product should be separated from the soil, properly stored, profiled, and disposed of at an approved recycling/disposal facility.
8. For any soils hauled off Airport property, the Contractor shall be responsible for the legal disposal of any soil. The Contractor shall implement and maintain the following:
  - a. A form, signed by the Contractor and haul truck driver. The form shall contain the following information:
    - i. The date the material is being taken off Airport property.
    - ii. The name of the haul trucking company.
    - iii. The haul truck number and license plate number.
    - iv. The quantity of material being loaded into the haul truck.
    - v. The disposal facility or location of where the material is to be taken.
    - vi. The time the truck left the project site.
  - b. The form and waste manifest from the HDOH permitted facility shall be provided to the Engineer or its representative by the close of the next working day. The Contractor shall verify that the quantity of material loaded into the truck, as indicated on the form, exactly matches the quantity of material disposed at the HDOH permitted facility, as indicated on the waste manifest.

- c. The Contractor shall maintain a log that summarizes each form and waste manifest for ease of tracking and monitoring.
  - d. **All forms, waste manifest, and summary log shall be a condition of payment being made to the Contractor and shall be submitted with each progress payment. Failure to submit the above and/or should any quantity of material loaded into the truck, as indicated on the form, not exactly match the quantity of material disposed at the HDOH permitted facility, as indicated on the waste manifest, shall be reason for the State to withhold payment to the Contractor.**
9. Excavated soils can be reused onsite (within the construction site boundaries) with the prior approval of the DOTA AIR-EE, HDOH HEER Office, and subject to the following conditions:
- a. Representative soil samples have been taken and tested in accordance with HDOH standards and regulations.
  - b. The contaminated soil can only be reused within proximity of its original excavation.
  - c. The contaminated soil is placed within areas more than 150 meters from surface water and drainage features.
  - d. The contaminated soil cannot be placed beneath or within the footprint of a planned building structure.
  - e. The contaminated soil can only be placed at an elevation above the tidally influenced high water table and at least 1-foot below the finish surface grade. The more highly impacted soil should be placed at the bottom of the excavation and the cleanest soil at the top of the excavation. At least 1-foot of clean soil must be placed as the final backfill layer at the top. The excavation shall then be capped with an impervious layer, such as concrete and asphalt.
  - f. The contaminated soil cannot contain any free oil, oil sheens, oil stains, or total petroleum hydrocarbon (TPH) concentrations exceeding 5,000 parts per million (ppm).
  - g. The contaminated soil is not considered a hazardous waste pursuant to Federal and State laws.
  - h. Contaminated soil shall not be reused in areas that are uncontaminated.
10. Excavated soils can be reused offsite (off Airports property) with the prior approval of the DOTA AIR-EE, HDOH HEER Office, and subject to the following conditions:
- a. Representative soil samples have been taken and tested in accordance with HDOH standards and regulations.

- b. The work shall be performed in accordance to the latest edition of the HDOH's *Guidance for Soil Stockpile Characterization and Evaluation of Imported and Exported Fill Material*.
  - c. A signed agreement with the receiving facility acknowledging the test results of the soil samples and acceptance of the soil is required to be submitted to the DOTA Engineer and DOTA AIR-EE ten (10) calendar days prior to hauling of the soil to the receiving facility.
  - d. The contaminated soil shall not contain any free oil, oil sheens, oil stains, or total petroleum hydrocarbon (TPH) concentrations exceeding 5,000 parts per million (ppm).
  - e. The contaminated soil is not considered a hazardous waste pursuant to Federal and State laws.
11. All soil that is reused onsite or offsite shall be included in the Closeout Report. The report shall include, at a minimum, a copy of the signed agreement from the receiving facility accepting the soil, a copy of the soil test results, the quantity of soil received by the facility, a location map of the reused soil including GPS coordinates of its limits, the depth and thickness of the soil's placement, a brief description of the purpose of the soil's re-use, and photos of the site conditions after placement has been completed.

## B. GROUNDWATER MANAGEMENT

Soil and groundwater may be impacted by petroleum hydrocarbons, dissolved metals, and/or pesticides, and may be encountered during soil excavation.

1. The disturbance of contaminated groundwater shall be performed in accordance with the approved Work Plan, DOTA EHE-EHMP, or Site-Specific EHMP, where applicable. HDOH HEER Office will determine whether additional sampling is required.
2. If contaminated groundwater is uncovered at a previously unknown source or site on the project, the Contractor shall immediately notify the DOTA Engineer, DOTA AIR-EE, and HDOH HEER Office of its discovery. Provide a location map with GPS coordinates and approximate depth of the groundwater (bgs) at which the discovery was encountered.
3. During excavation and disturbance of impacted groundwater, all workers, supervisory personnel, subcontractors and consultants must take precautionary measures as necessary to prevent exposure of the workers and the general public to COCs and inhalation of associated vapors. Free product, sheen, and impacted groundwater must be managed properly.
4. Groundwater that exhibits evidence of possible contamination, i.e., odor, visual sheen, free product, coloration, and PID measurement, shall be properly stored when removed from the ground. Storage devices shall be watertight and leak-free to prevent discharge of the water into the surrounding ground, drainage system, and surface waters.

When disconnecting pipes and hoses from storage devices and equipment, residual waters contained in the pipes and hoses shall also be prevented from discharging into the surrounding ground, drainage system, and surface waters.

5. Representative water samples shall be taken and tested in accordance with Federal and State guidelines, standards, and regulations.
6. If free product is present in the extracted groundwater, it must be separated from the groundwater, profiled, and disposed of at an HDOH approved recycling/disposal facility. Free product shall not be moved from one excavation to another. Engineering measures shall be taken to prevent the transfer of the free product during dewatering. Under no circumstances shall water contaminated with free product be discharged from a dewatering pit.
7. At least once daily, remove oil observed floating on the groundwater during excavation activities using a vacuum truck, absorbent pad, or other methods approved by HDOH HEER Office. Excavations shall not be backfilled until the floating oil is removed to the maximum extent practicable, which is when further use of vacuum trucks, absorbent pads, or other approved methods do not result in further floating oil removal. Backfilling of any excavation shall not occur without concurrence from DOTA AIR-EE and HDOH HEER Office.
8. Avoid any releases of contaminated groundwater to surface water bodies or areas beyond the work area.
9. Groundwater shall only be re-infiltrated in the ground with the prior approval of DOTA AIR-EE and HDOH HEER Office, and subject to the following conditions:
  - a. Within 200-feet of its original location or source and returned to the same aquifer which is not a current or potential drinking water source. Re-infiltration shall not contaminate uncontaminated areas.
  - b. More than 150 meters from surface waters, drainage features, and drainage structures.
  - c. Groundwater does not contain any gross contaminants.
  - d. If petroleum free product is present in the groundwater, the free product shall be removed prior to transfer of the groundwater to the re-infiltration site. Free product shall be removed at least once daily until no free product is observed after 24 hours. The free product shall be disposed at an HDOH-approved facility.
  - e. Groundwater is not considered a hazardous waste pursuant to Federal and State law.
  - f. Re-infiltration shall be conducted at a slow enough rate so that it does not flow past the designated infiltration area, enter storm drains, or impact surface water in the area.
  - g. If discharging to a re-infiltration trench, the trench must not be an

underground injection control (UIC) well by HDOH's Safe Drinking Water Branch (SDWB) definitions. If some part of the trench system is deemed to be a UIC well, then the whole system shall be considered an injection well.

- h. Advance clearance from HDOH SDWB is required if a re-infiltration trench is deeper than 10 feet.
  - i. If a UIC well is used for re-infiltration, the Contractor is responsible to obtain the necessary permits, including, but not limited to, HDOH's UIC Permit. The Contractor shall meet and comply with all permit requirements, including, but not limited to, well construction, placement, use, and closure.
10. Under circumstances where contaminated groundwater cannot be re-infiltrated, proper disposal must be conducted with the prior approval of the DOTA AIR-EE, HDOH SDWB, HDOH Solid and Hazardous Waste Branch (SHWB), and HDOH HEER Office. This is also subject to the following conditions:
- a. Discharge to the local or municipal sanitary sewer system after acquiring appropriate permit(s) from City and County (if applicable and if allowable by the receiving governmental agency) prior to discharge. If discharge water was generated within contaminated areas, additional coordination with HDOH HEER Office is required, and Aquatic Habitat Criteria (Chronic Toxicity) shall apply to discharge within these areas, in addition to any criteria applicable to the National Pollutant Discharge Elimination System (NPDES) permit or pretreatment facility. Water discharged to a sanitary sewer may be required to meet Water Quality Standards.
  - b. Notification to the appropriate agencies and other pertinent information related to the discharge must be provided upon request.
  - c. The Contractor is responsible for the legal disposal or discharge of any groundwater that is not re-infiltrated, and shall provide the DOTA AIR-EE with copies of waste manifests.
  - d. For any groundwater hauled off Airport property, the Contractor shall have representative samples taken and tested in accordance with HDOH guidelines, standards, and regulations. A copy of the groundwater test result shall be submitted to DOTA AIR-EE. The groundwater shall not be disposed offsite without the approval of DOTA AIR-EE and the HDOH permitted facility that is receiving the groundwater. Furnish documentation from the receiving facility indicating that they acknowledge the groundwater test results, including their approval to dispose the groundwater at their facility.

### C. RELEASE REPORTING

Encountering previously unknown, suspected, or confirmed contaminated soil or groundwater during subsurface construction activities is considered a release and shall be reported to HDOH HEER Office (phone: 808-586-4249, or after hours at 808-236-8200). Copies of the HDOH Release Report, HDOH issued Release Number, and email correspondence (if applicable), shall be furnished to the DOTA Engineer

and DOTA AIR-EE.

1. Upon the discovery of contaminated soil and/or groundwater, the Contractor shall immediately notify the DOTA Engineer, DOTA AIR-EE, and HDOH HEER Office.
2. A reportable release of hazardous substances or contaminated soil or groundwater may be indicated by, but not limited to, any of the following:
  - A petroleum sheen on the groundwater in an excavation.
  - Any free product that appears on groundwater.
  - Visual or olfactory evidence of contamination (e.g., unusual discoloration, buried containers, fumes, unknown liquids).
3. Comply with DOTA and HDOH HEER Office requirements. A written report shall be provided to the HDOH HEER Office. The *Hawaii Hazardous Substance Written Follow-up Notification Form* is provided in the DOTA EHE-EHMP, Appendix B.1. Photos shall be included to document the incident. The Contractor shall keep a copy of the completed Form B.1 and provide copies of the written report to the DOTA Engineer and DOTA AIR-EE.
4. If free product is encountered, report the release in accordance with HAR § 11-451.

Releases that occur during construction activities or releases due to unforeseen events (spill) shall also be reported.

1. Report all spills to immediately to AIR-EE, State Engineer, and appropriate airport personnel and regulatory agencies (if applicable) following the DOTA Spill Reporting Fact Sheets for each airport. Spill Reporting Fact Sheets can be found on DOTA's Environmental Webpage for Construction site Runoff at <https://hidot.hawaii.gov/airports/doing-business/engineering/environmental/construction-site-runoff-control-program/>.
2. In the event of a release of a hazardous substance that causes an imminent threat to human health or the environment, the first call shall be to 911.
3. Small spills of petroleum or hazardous substances (less than 25 gallons) which are capable of being cleaned up within 72 hours and do not threaten ground or surface waters shall be cleaned up immediately.
4. Report spills of a certain size (e.g., volume of greater than 25 gallons or not contained within 72 hours), per HAR § 11-451, to HDOH HEER Office and the National Response Center immediately. Comply with the HDOH HEER Office requirements. A written report shall be provided to the HDOH HEER Office within 30 calendar days of a Reportable Quantity spill cleanup. The *Hawaii Hazardous Substance Written Follow-up Notification Form* is provided in the DOTA EHE-EHMP, Appendix B.1. Photos shall be included to document the incident. The Contractor shall keep a copy of the completed Form B.1, and provide copies of the written report, the HDOH issued Release Number, and email correspondence (if applicable) to the DOTA Engineer and DOTA AIR-EE.
5. Any spill that enters a body of water, onto an adjoining shoreline, or discharges

into the storm drain system, HDOH CWB must also be immediately notified and the National Response Center notified within 24 hours. Report significant spills to the U.S. Coast Guard.

#### D. FINAL CLEANUP

1. When work which disturbs contaminated soil has been completed, the State will visually inspect the work area for evidence of contaminated materials and direct the Contractor to clean and remove remaining contaminated materials. The Contractor shall not dismantle the work area boundaries prior to authorization by the State.
2. Any equipment which contacts contaminated materials shall be cleaned with a water spray immediately upon completion of work. The wash location shall be located immediately adjacent to the contaminated area. All wash water and solid waste shall be disposed of in accordance with the Work Plan. The wash water shall not be allowed to discharge into the drainage system and surface waters.

#### E. AIR MONITORING

1. Air monitoring shall be conducted when petroleum-contaminated soil (PCS), contaminated groundwater, free product, or chlorinated solvents (e.g., PCE, TCE, etc.) is present in an excavated area. The monitoring shall include both work area and perimeter measurements of volatile organic compound (VOC) vapors. Appropriate response actions shall be taken in conformance to Federal and State regulatory requirements and guidelines. The response actions shall include ensuring that on-site workers have the appropriate level of PPE and the general public is not affected adversely.
2. Air monitoring shall be conducted with a conventional photoionization detector (PID) to measure total VOC vapor concentrations. If high levels of benzene are anticipated, an Ultra-Rae PID, which is benzene-specific, shall also be used.
3. If toxic gases are a potential concern, air monitoring of the lower explosive limit (LEL) shall be conducted using a multi-gas meter to determine if a hazardous atmosphere exists.
4. Air monitoring shall be conducted for at least three (3) full 8-hour shifts to establish a negative exposure assessment for worker's exposure to airborne contaminants. After the establishment of the negative worker's exposure, periodic monitoring shall be conducted once every seven (7) calendar days to document worker exposure for the duration of the contaminated soil work.
5. Work area and perimeter air monitoring shall be conducted throughout the entire duration of the contaminated soil work to ensure unprotected personnel are not exposed above permissible exposure limits at all times. If the outside boundary levels are at or exceed permissible exposure limits, work shall be stopped, and the Contractor's Qualified Environmental Professional and DOTA Engineer shall be immediately contacted to address the situation causing the increased levels.
6. Submit air sampling results to the DOTA Engineer within five (5) calendar days after the samples are collected, signed by the testing laboratory employee

performing the air monitoring.

F. UNDERGROUND STORAGE TANKS (UST) AND UTILITY PIPES

1. For any UST or pipeline discovered or planned removal, the nature of the UST or pipeline, and whether they are inactive, shall be determined prior to removal. Immediately notify the DOTA Engineer and DOTA AIR-EE of the discovery.

If unanticipated petroleum pipelines are discovered, contact HDOH HEER Office within 24 hours after encountering them.

2. The Contractor shall record field observations of the UST and pipelines. These observations shall include, but are not limited to, the following:
  - a. Location relative to fixed landmarks, including GPS coordinates. Provide a location map that shows the UST and pipelines that were encountered. The map must include a North arrow and a scale.
  - b. Depth, diameter, length, and type of pipe, if applicable. Describe the condition of the pipe.
  - c. Type of fuel or product, including analytical laboratory reports for the product that is recovered.
  - d. Beginning and ending fluid levels, if applicable.
  - e. Volume of each type of product removed.
  - f. Flow rates, if applicable.
  - g. Direction of flow.
  - h. Detailed photographs.
  - i. Detailed description of actions taken following the discovery, such as, cutting, product removal, and disposal.

Provide records of the field observations to the DOTA Engineer, DOTA AIR-EE, and HDOH HEER Office.

3. Prior to removal of a UST, the Contractor shall prepare and submit to the DOTA Engineer, for review by DOTA AIR-EE, a Site-Specific plan. All work associated with USTs shall be in compliance with HAR § 11-280.1 requirements, and HDOH HEER Office and HDOH SHWB requirements.

The contractor shall also complete the HDOH *Notice of Intent to Close Underground Storage Tanks* form and submit it to the DOTA Engineer for submission to HDOH SHWB (UST Section) by DOTA AIR-EE.

Prior to the removal of the UST, the Contractor shall receive approval from DOTA AIR-EE and HDOH HEER Office.

4. The UST or pipeline segment must be drained of its content or determined that it is empty of liquids or flammable vapors prior to the removal. Any petroleum fluids recovered must be representatively sampled and tested to determine how they can be recycled or disposed in full accordance with HAR § 11-58.1 and § 11-260–279, and any other Federal and State regulations.
5. Only personnel knowledgeable and trained in pipeline and UST removal shall cut, drain, and remove USTs and pipelines. Prior to cutting, plastic sheeting and absorbent material shall be placed below and adjacent to the cutting location. Any residual fluid in the UST or pipeline must be properly contained on the sheeting and prevented from discharging into the surrounding soil or entering any drainage system and surface waters.
6. The cut-off ends of the pipeline segments, that remain in-place, must be filled with concrete and appropriately sealed to prevent any potential leakage and contact with groundwater.
7. If the waste pipe or UST are to be stored onsite prior to disposal, the area shall be lined with polyethylene plastic sheeting, 10 mil or thicker, and bermed to contain any free product. Some viscous products may appear to be immobile, however, after exposed to atmosphere heating, can liquefy. The waste pipe segment shall be stored on appropriate dunnage with the ends of the pipe sealed or covered to protect the interior of the pipe from contact with rainwater and wind.
8. All removed pipelines and USTs shall be properly disposed or recycled.
9. For USTs, a UST Removal Report including all sampling activities required under HAR § 11-280.1 shall be prepared and submitted to the DOTA Engineer, DOTA AIR-EE, and HDOH SHWB (UST Section).

### 3.4 POST-CONSTRUCTION REQUIREMENTS

- A. Submit the following within 30 calendar days after work is completed.
  1. Close-out Report
    - a. A signed certificate stating that the removal and disposal of all contaminated materials were completed in accordance with the Contractor's approved Work Plan or C-EHMP Addendum, and all applicable Federal, State, and local rules and regulations.
    - b. All approved DOTA EHE-EHMP deviation request forms. (Reference Appendix B of the DOTA EHE-EHMP.)
    - c. All Site-Specific EHMP, if applicable.
    - d. All testing, laboratory results, and reports for any soil, groundwater, soil vapor, UST, pipeline, and other samplings taken.
    - e. All disposal forms, waste manifests, and summary logs.

- f. Any results from project air monitoring.
- g. Record of Field Observations, including location map with GPS coordinates, limits, and depths of any contaminated media (soil, groundwater, etc.) that were encountered at previously unknown source or sites on the project. Include a copy of the completed *Hawaii Hazardous Substance Written Follow-up Notification* form that was submitted to HDOH and all other associated documents.
- h. If any contaminated soil was removed offsite (off of Airport Property), at a minimum, include the following:
  - A copy of the signed agreement from the receiving facility acknowledging the test result of the soil samples and indicating acceptance of the soil for reuse.
  - Copies of the test results of the soil sampling.
- i. If any contaminated soil was re-used onsite (within the construction site boundaries), at a minimum, include the following:
  - Copies of the test results of the soil sampling.
  - The quantity of soil that is re-used on-site.
  - Location map of the re-used soil. Include GPS coordinates of its limits, if the area is accessible.
  - A brief description of the purpose of the re-used soil (e.g., general fill, utility trench backfill material, etc.). Include the depth and thickness of its placement.
  - Photos of the site after placement of the re-use soil has been completed.
- j. Record of Field Observation of any unanticipated UST or pipeline discovered during construction activities, including a copy of the completed HDOH *Notice of Intent to Close Underground Storage Tanks* form and all other associated documents.

The Close-out Report shall be by each individual contaminated media and shall include all appropriate documentations. The Close-out Reports for each contaminated media can be submitted separately or combined in a 3-ring binder with divider tabs.

PART 4 – MEASUREMENT AND PAYMENT

4.1 BASIS OF MEASUREMENT AND PAYMENT

Work under this Section will be paid for under the various contract items as shown below.

For ALLOWANCE items in the Proposal Schedule, the allowance is an estimate and the amount shall not exceed the maximum amount shown in the Proposal Schedule. Payment shall be the actual cost as invoiced by the Contractor and approved by the DOTA Engineer. The Contractor shall be allowed to include overhead, profit, insurance and/or other mark-ups, as stipulated in Section 9.5 of the 2016 General Provisions for Construction Projects, Air and Water Transportation Facilities Divisions.

<u>Item No.</u>	<u>Item</u>	<u>Unit</u>
01562.1	Management of Contaminated Medias	Allowance

**Should the DOTA receive reports of any illegal dumping of material, and if illegal dumping is confirmed to have occurred, the DOTA will assess a Liquated Damage amount of \$5,000 per truck per day, until the illegal dumped material has been cleaned up or the incident has been remedied to the HDOH’s concurrence. The Contractor shall not be entitled to recover any Liquidated Damages assessed, even after the non-compliance has been corrected.**

**The Contractor shall also be responsible for all citations, fines, and penalties levied by HDOH or EPA against the State due to the Contractor’s failure to properly manage contaminated medias, including non-compliance with the DOTA EHE-EHMP, DOTA Site-Specific EHMP, or C-EHMP Addendum.** The Contractor shall reimburse the State within 30 calendar days for the full amount of outstanding cost that the State has incurred, or the State shall deduct all incurred costs from the Contractor’s monthly progress payments.

If the Contractor fails to satisfactorily address the non-compliance item, DOTA reserves the right to employ outside assistance or use the State’s own labor forces to provide necessary corrective measures. The Contractor shall be fully responsible for all cost and time. The State shall charge the Contractor such incurred costs plus any associated project engineering costs and shall make appropriate deductions from the Contractor’s monthly progress payment.

END OF SECTION

## SECTION 01565 – SECURITY MEASURES

### PART 1 – GENERAL

#### 1.01 RELATED DOCUMENTS

The General Provisions for Construction Projects (2016), Special Provisions and General Requirements of the Specifications, apply to the work specified in this Section.

#### 1.02 DESCRIPTION

The Contractor shall incorporate the State's airport security measures as part of his work. The Contractor shall adhere to established and enhanced security procedures, as mandated by the State and FAA, throughout the course of this Contract.

#### 1.03 SUBMITTALS

Submit a security plan that addresses the conditions set forth in this Contract. Said plan shall contain, at a minimum, a plan of the project scope with locations of construction barricades with secured entry/exits, identification of locations requiring guards, Contractor measures to ensure security of worksite and personnel and procedures to ensure the containment of the worksite from unauthorized personnel. This package shall be submitted within 14 calendar days after award of the Contract.

### PART 2 – PRODUCTS (Not Used)

### PART 3 – EXECUTION

#### 3.01 SECURITY

- A. Obtain airport security identification badges for all employees working on this project and Air Operations Area (AOA) decals for all vehicles entering the AOA area in accordance to the requirements stated in the Special Provisions, Section 7.21 – “PUBLIC CONVENIENCE AND SAFETY”. All requests for badges and AOA decals shall be submitted in writing to the Airport District Manager through the Engineer within 14 calendar days after award of the Contract. Only authorized personnel working on this project shall be allowed to obtain badges. The Contractor shall be responsible to pay for all costs associated with complying with airport security requirements, including obtaining airport security identification badges.

Currently, the fee to obtain a new airport identification badge is \$100.00, but due to the changing fee structure of these services, the Contractor shall inquire with the Daniel K. Inouye International Airport AOA badge

and ramp license office at (808) 836-6548. For other Airport Districts cost inquiries should be made the District Manager's office.

If access is required to the Honolulu International Arrivals Building, inquiries shall be made to the Bureau of Customs and Border Patrol at (808) 861-8642 for additional bonding requirements.

- B. The Contractor shall comply with all existing and proposed airport security initiative requirements. Contractor may be subject to civil penalties up to \$35,000.00 for each security violation.
- C. The Contractor shall protect work areas from theft, vandalism, and unauthorized entry. Ensure that proper methods are undertaken to secure tools, materials, and equipment from the public.
- D. All vehicles entering the AOA through any of the Airport Access Check Points may be subject to search. The Contractor shall allow extra time for these inspections and be able to provide personnel, as required, to assist Airport security personnel during the inspections.
- E. If required by the State, the Contractor will be responsible for the posting of guards at access points where the construction traffic may compromise the integrity of the airport security. Payment for posting of security guards required by the State shall be paid for as an allowance item in the Proposal Schedule. The Contractor shall submit the name and qualifications of the security company to the Engineer for review prior to hiring the security company. The security company shall have extensive experience in working on airports and knowledgeable in airport security procedures within the State of Hawaii.

PART 4 - MEASUREMENT AND PAYMENT

4.01 METHOD OF MEASUREMENT

No measurement shall be made for the items in this Section.

4.02 BASIS OF PAYMENT

Work under this Section, except for posting security guards, shall be considered incidental to, and included in the bid prices for the various items of work in this project.

Posting of security guards required by the State shall be paid for under an allowance item in the Proposal Schedule. The allowance is an estimate, and the amount shall not exceed the maximum amount shown in the proposal schedule. Additional charges by the Contractor for overhead, coordination, profit, insurances, and other incidental expenses shall not be allowed. These shall be included in the Contractor's lump sum bid price.

<u>Item No.</u>	<u>Description</u>	<u>Unit Price</u>
01565.1	Security Measures	Allowance

END OF SECTION

## SECTION 01580 - TEMPORARY FACILITIES AND UTILITIES

### PART 1 - GENERAL

#### 1.01 RELATED DOCUMENTS

The General Provisions for Construction Projects (2016), Special Provisions and General Requirements of the Specifications, apply to the work specified in this section.

#### 1.02 DESCRIPTION

This item shall consist of arranging and maintaining all utilities including, but not limited to, water, electricity, sewage disposal and telephone communications in the work area which the Contractor and Engineer deems necessary to meet the requirements of the work under the contract.

### PART 2 - PRODUCTS (Not Used)

### PART 3 - EXECUTION

#### 3.01 TEMPORARY UTILITIES DURING CONSTRUCTION

- A. Water and Sanitation: The Contractor shall provide temporary drinking water and sanitary facilities for the field personnel. The facilities shall be in accordance with the applicable health regulations and shall be maintained clean and operable until the conclusion of the construction work.
- B. Telephone: The Contractor shall have a telephone available for the State's use for communications with field personnel. Cellular telephones are acceptable. The Contractor shall install the telephone immediately upon starting work and maintain service until the project is completed. All costs associated with obtaining and maintaining telephone service shall be borne by the Contractor.
- C. Electricity: Contractor shall obtain or provide temporary electric power and shall pay for all connections and energy charges incurred during construction.
- D. Metering: Water and electrical services shall be metered and payment for meters and services shall be borne by the Contractor. Temporary connections for water shall include installation of a meter and backflow preventer at the point of connection according to State standards at the Contractor's cost. The Contractor shall submit requests for temporary connections in writing to the Engineer 14 calendar days prior to the connection and shall include a description of work and a sketch of the proposed installation.

PART 4 – MEASUREMENT AND PAYMENT

4.01 BASIS OF MEASUREMENT AND PAYMENT

Work under this section will not be measured nor paid for separately but shall be considered incidental to and included in the bid prices for the various items of work in this project.

END OF SECTION

## SECTION 01700 – MOBILIZATION, DEMOBILIZATION

### PART 1 - GENERAL

#### 1.01 RELATED DOCUMENTS

The General Provisions for Construction Projects (2016), Special Provisions and General Requirements of the Specifications, apply to the work specified in this section.

#### 1.02 GENERAL REQUIREMENTS

- A. Section 699 of "Hawaii Standard Specifications for Road, Bridge, and Public Works Construction, 1994," are hereby incorporated into and made a part of these specifications by reference unless otherwise modified hereinafter.

#### 1.03 MOBILIZATION

- A. The Contractor shall mobilize and transport his construction plant and equipment including materials and supplies for operation to the site of work, construct temporary buildings and facilities as necessary, and assemble the equipment at the site as soon as possible after receipt of Notice to Proceed, subject to the provisions of the General Provisions.

#### 1.04 DEMOBILIZATION

- A. The Contractor shall demobilize and transport his construction plant and equipment including materials, supplies and temporary buildings off the site as soon as possible after construction is completed. Demobilization shall include all cleanup required under this contract and as directed by the Engineer. Demobilization and final cleanup shall be completed prior to final acceptance.

#### 1.05 PERFORMANCE BOND

- A. The Contractor shall file and pay for the performance and payment bonds according to Section 3.5 of the Special Provisions, except that the value of the bonds shall equal one hundred percent (100%) of the amount of the contract basic bid amount plus one hundred percent (100%) of the amount of the extra work.

Payment for the Contractor's bond premium will be made as part of mobilization in accordance to the terms stated in Part 4 below.

### PART 2 - PRODUCTS (Not Used)

### PART 3 - EXECUTION (Not Used)

PART 4 - MEASUREMENT AND PAYMENT

4.01 METHOD OF MEASUREMENT

- A. Mobilization shall not be measured for payment. The maximum bid allowed for "Mobilization" is an amount not to exceed six (6) percent of the sum of all items (excluding this item and all Allowances). If the proposal submitted by the bidder indicates an amount in excess of the allowable maximum, the indicated amount or amounts shall be reduced to the allowable maximum; the "Sum of All Items," in the proposal schedule shall be adjusted to reflect any such reduction. For the purposes of comparing bids and determining the contract price to be inserted in the contract awarded to the bidder, if any is so awarded, the "Sum of All Items" adjusted in accordance with the foregoing shall be used and the bidder's proposal shall be deemed to have been submitted for the amounts as reduced and adjusted in accordance herewith."
  
- B. Demobilization will not be measured for payment.

4.02 BASIS OF PAYMENT

- A. Mobilization will be paid for at the contract lump sum price under Mobilization. Partial payment will be made as follows:
  - 1. When 2 1/2 percent of the original contract amount is earned, 50 percent of the bid amount will be paid.
  - 2. When 5 percent of the original contract amount is earned, 75 percent of the bid amount will be paid.
  - 3. When 10 percent of the original contract amount is earned, 100 percent of the bid amount will be paid.

Nothing herein shall be construed to limit or preclude partial payments otherwise provided by the contract.

<u>Item No.</u>	<u>Description</u>	<u>Unit Price</u>
01700.1	Mobilization (Not to exceed 6% of sum of all items, excluding this item, all allowances and force account items)	Lump Sum

END OF SECTION

## DIVISION 10 - SPECIALTIES

### SECTION 10222 - OPERABLE PARTITIONS

#### PART 1 - GENERAL

##### 1.01 RELATED DOCUMENTS

- A. The General Provisions of the contract, including the General Provisions for Construction Projects (2016) and General Requirements of the Specifications, apply to the work specified in this section.
- B. Operable Partitions
  - 1. Single panel partitions, 3 inch (76 mm) thick panels. (931 Premier) (931 Legacy)
  - 2. Single panel partitions, 4 inch (108 mm) thick panels. (Encore) (Encore Flex)
  - 3. Single panel partitions, fire-rated. (911 Legacy)
  - 4. Paired panel partitions, 3 inch (76 mm) thick panels. (932 Premier) (932 Legacy)
  - 5. Paired panel partitions, 4 inch (102 mm) thick panels. (Encore)
  - 6. Paired panel partitions, fire-rated. (912 Legacy)
  - 7. Continuously hinged panel partitions, electric operation. (933 Premier) (933E Legacy)
  - 8. Continuously hinged panel partitions, electric operation. (Encore 20) (Encore 14 or 30)
  - 9. Accordion folding doors. Soundmaster Modernfold

##### 1.02 DESCRIPTION

- 1. Related Sections:
  - a. Section 03300 - Cast-in-Place Concrete concrete tolerances required.
  - b. Section 05500 - Metal Fabrications primary structural support, including pre punching of support members by steel supplier in accordance with template supplied by operable partition supplier's template.
  - c. Section 06100 - Rough Carpentry wood framing and supports and blocking at head and jambs as required.

### 1.03 SUBMITTALS

- A. Submit under provisions of SECTION 01300 - SUBMITTALS
- B. Product Data: Material descriptions, construction details, finishes, installation details, and operating instructions for each type of operable partition, component, and accessory.
- C. Shop Drawings: Location and extent of operable partitions. Plans, elevations, sections, details, attachments to other construction, and accessories. Dimensions, weights, conditions at openings, and at storage areas, and required installation, storage, and operating clearances. Location and installation requirements for hardware and track, including floor tolerances required and direction of travel. Blocking provided by others.
- D. Setting Drawings: Show imbedded items and cutouts required in other work, including support beam punching template.
- E. Samples: Color samples demonstrating full range of finishes available. Verification samples shall be available in same thickness and material indicated for the work.
- F. Manufacturer's Certificates: Certify products meet or exceed specified requirements.
- G. Closeout Submittals: Provide manufacturer's maintenance instructions that include recommendations for periodic checking and maintenance of all components.

### 1.04 QUALITY ASSURANCE

- A. Installer Qualifications: Experienced installer, certified by the operable partition manufacturer, as qualified to install the manufacturer's partition systems for work similar in material, design, and extent to that indicated for this Project.
- B. Acoustical Performance: Test operable partitions in accordance with ASTM E 90 test procedure to attain no less than the STC rating specified. Provide a complete and unedited written test report by the testing laboratory upon request.
- C. Preparation of Opening: Conform to ASTM E 557.

### 1.05 DELIVERY, STORAGE, AND HANDLING

- A. Clearly mark packages and panels with numbering systems used on Shop Drawings. Do not use permanent markings on panels.
- B. Protect panels during delivery, storage, and handling to comply with manufacturer's instructions and as required to prevent damage.

## 1.06 WARRANTY

- A. Provide operable partition manufacturer's written warranty agreeing to repair or replace components with manufacturing defects for a period of two years minimum.
- B. Contractors Surety shall not be held liable beyond 2 years from project acceptance date.

## PART 2 PRODUCTS

### 2.01 MANUFACTURERS

Acceptable Manufacturers Or Approved Equals:

- A. Modernfold, Inc., which is located at: 215 W. New Rd.; Greenfield, IN 46140
- B. Hurcor, Inc. 2101 Kennedy Road; Janesville, WI 53545
- C. Substitutions: Permitted.
- D. Requests for substitutions will be considered in accordance with provisions of SECTION 01300 - SUBMITTALS

### 2.02 ACCORDION FOLDING DOORS (SOUNDMASTER)

- A. Product: Soundmaster No. 12 Accordion Folding Partition by Modernfold, Inc. Manually operated, top supported. STC: 40. Or Approved Equal.
- B. Construction:
  - 1. Steel Hinge Plates: Welded to 3/16 inch (5 mm) vertical steel rods, with a single row of plates at bottom and top with intermediate rows at 42 inch (1067 mm) on center.
  - 2. Partitions 10 ft (3048 mm) High or Over: Double row of hinge plates at the top.
  - 3. Frame Assembly Support: High tensile alloy steel trolley yoke, functioning as a hinge pin at required intervals.
  - 4. Sound Transmission of Folding Partition: Tested by an independent acoustical laboratory, in accordance with ASTM E90, classified in accordance with ASTM E413. prevent unraveling or fray of material.
  - 5. Partition Face Finish: Wall covering and upholstery fabric. Stain resistant surface treatment.
- C. Sound Seals:
  - 1. Pairs of three-layer flexible sweep strips at top and bottom. Vertical Female Sound Channel: Polyurethane foam lined.
  - 2. Sound Insulation: 24-gage, V-grooved steel panels and heavy duty flame resistant acoustical membrane. Each panel attaches to frame with steel leaf fasteners.

3. Pairs of Flexible Sweep Strips: At top and bottom of partition. Air release for air trapped within the folding partition is accomplished during operation by a series of 3/8 inch (9.5 mm) diameter holes through the lead post molding.
- D. Hardware: Hand Pulls: Die-cast zinc. Grip type. Finish: satin chrome.
  - E. Suspension System: Track and trolley sizes matched to size of partitions.
    1. Tracks: Continuous "C" channel shaped track, connected to structural support.
    2. Carriers: Accordion partitions suspended from track by two-wheel intermediate and four-wheel lead trolley assemblies.
    3. System No. 5.
    4. System No. 6.
    5. System No. 7.
  - F. Jamb-Lock: Back post secured to wall with the Jamb-Lock concealed within the back post. A quick means of releasing and reattaching partition for cleaning and decorative purposes.
  - G. Manually Operated Partition Locks: Master-keyed cylinders by others. Locks: integral part of the pull. Satin chrome hand pulls
    1. Manufacturer's master-keyed locks.

### PART 3 EXECUTION

#### 3.01 EXAMINATION

- A. Do not begin installation until supports and substrates have been properly prepared.
- B. If substrate preparation is the responsibility of another installer, notify Architect of unsatisfactory preparation before proceeding.

#### 3.02 PREPARATION

- A. Clean surfaces thoroughly prior to installation.
- B. Prepare surfaces using the methods recommended by the manufacturer for achieving the best result for the substrate under the project conditions.

#### 3.03 INSTALLATION

- A. Install in accordance with manufacturer's instructions and ASTM E 557 installation procedures. Test for proper operation and make necessary adjustments until satisfactory results are obtained.

#### 3.04 PROTECTION

- A. Protect installed products until completion of project.
- B. Touch-up, repair or replace damaged products before Substantial Completion.

PART 4 - MEASUREMENT AND PAYMENT

4.01 BASIS OF MEASUREMENT AND PAYMENT

- A. Work under this section will not be measured for payment but will be paid for at the Contract Lum Sum Price.

<u>Item No.</u>	<u>Description</u>	<u>Unit Price</u>
10222	Operable Partitions	Lump Sum

END OF SECTION

STATE OF HAWAII  
DEPARTMENT OF TRANSPORTATION  
AIRPORTS

EXHIBIT A



Airports Division  
DEPARTMENT OF TRANSPORTATION  
STATE OF HAWAII

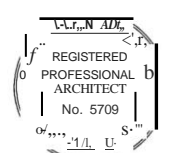

AS PREPARED BY  
MY SUPERVISION

DSGN. DRWN. CHKD. APPD.  
JA/AN BY AN JA

KEY PLAN / NOTES :

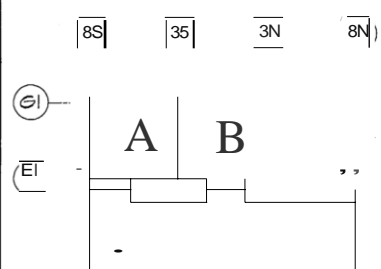

SECTOR PLAN

HALL TYPES

- H-1 SEE DET. 1/A-11
- H-1A SEE DET. 1/A-11
- 01-2 SEE DET. 2/A-11
- Y1-5 SEE DET. 5/A-11
- 01-5A SEE DET. 5/A-11
- 01-4 SEE DET. 5/A-25
- 01-5 SEE DET. 4/A-25
- EXISTING HALL

AIRPORTS DIVISION  
ADMINISTRATION OFFICES  
NEJAI INTER-ISLAND TERMINAL  
COMPLEX

AOI 123-24

PARTIAL SEVENTH LEVEL  
FLOOR PLAN - SECTOR C

DATE:  
APRIL 30, 11'12

DWG. NO.:  
A-4

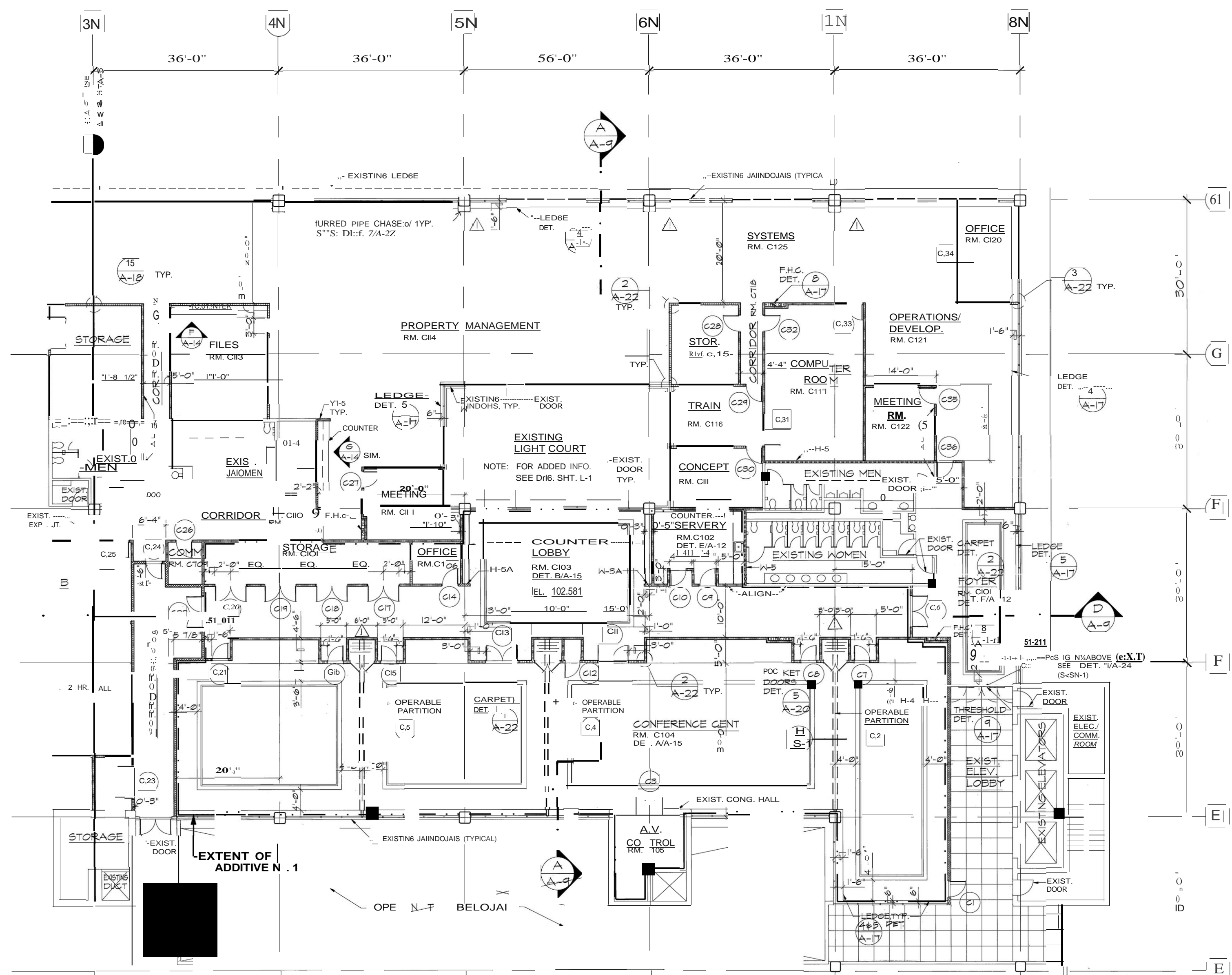

PARTIAL SEVENTH LEVEL FLOOR PLAN - SECTOR C

SCALE : 1/8" = 1'-0"

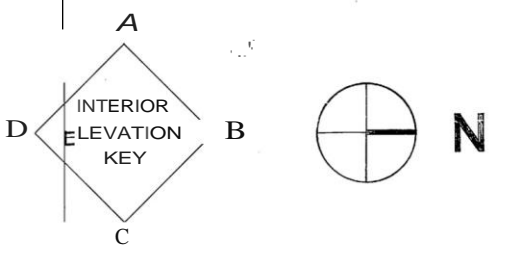

DATE: APRIL 30, 11'12  
DWG. NO.: A-4



Airports Division  
DEPARTMENT OF TRANSPORTATION  
STATE OF HAWAII



THIS WORK WAS PREPARED BY ME OR UNDER MY SUPERVISION  
DSGN. DRWN. CHKD. APPD.

DKF YKI DKF YK  
**KEY PLAN / NOTES**

**STRUCTURAL NOTES:**

- STRUCTURAL STEEL SHAPES AND PLATES SHALL MEET THE REQUIREMENTS OF ASTM A36 UNLESS NOTED OTHERWISE.
- WORKMANSHIP SHALL BE IN ACCORDANCE WITH THE LATEST AISC AND AWS CODES.
- ALL WELDING, WHETHER SHOP OR FIELD, SHALL BE DONE BY CERTIFIED WELDERS ONLY.
- ALL CONNECTIONS SHALL DEVELOP THE FULL STRENGTH OF MEMBERS CONNECTED UNLESS DETAILED OTHERWISE.
- UNLESS SHOWN OTHERWISE, ALL EMBEDDED BOLTS, ANCHORS, PLATES, INSERTS, ETC., SHALL BE HOT-DIPPED GALVANIZED AFTER FABRICATION.
- UNLESS SHOWN OTHERWISE, ALL CONNECTION BOLTS SHALL BE ASTM A307 BOLTS AND GALVANIZED.
- NO HOLES OTHER THAN THOSE SPECIALLY DETAILED SHALL BE ALLOWED THROUGH STRUCTURAL STEEL MEMBERS.
- WELDS SHALL BE MADE WITH ASTM A233, E-70 SERIES ELECTRODES FOR STEEL TO STEEL CONNECTIONS.
- ALL STRUCTURAL STEEL SHALL BE PAINTED WITH ONE COAT OF SHOP PAINT. DO NOT SHOP PAINT SURFACES TO BE EMBEDDED IN CONCRETE. TOUCH-UP PAINTING IN FIELD SHALL BE DONE AFTER ERECTION IS COMPLETED.

NO.	DATE	REVISIONS

**"AS-BUILT"**

RECORD DRAWING

**PROJECT TITLE :**

AIRPORTS DIVISION  
ADMINISTRATION OFFICE  
NEW INTER-ISLAND  
TERMINAL COMPLEX  
PROJECT NO. :

A01123-24  
**SHEET TITLE :**

OPERABLE PARTITION  
BRACING ELEVATIONS,  
DETAILS AND SECTIONS

DATE :  
APRIL 30, 1992  
DWG. NO. :

**S-1**

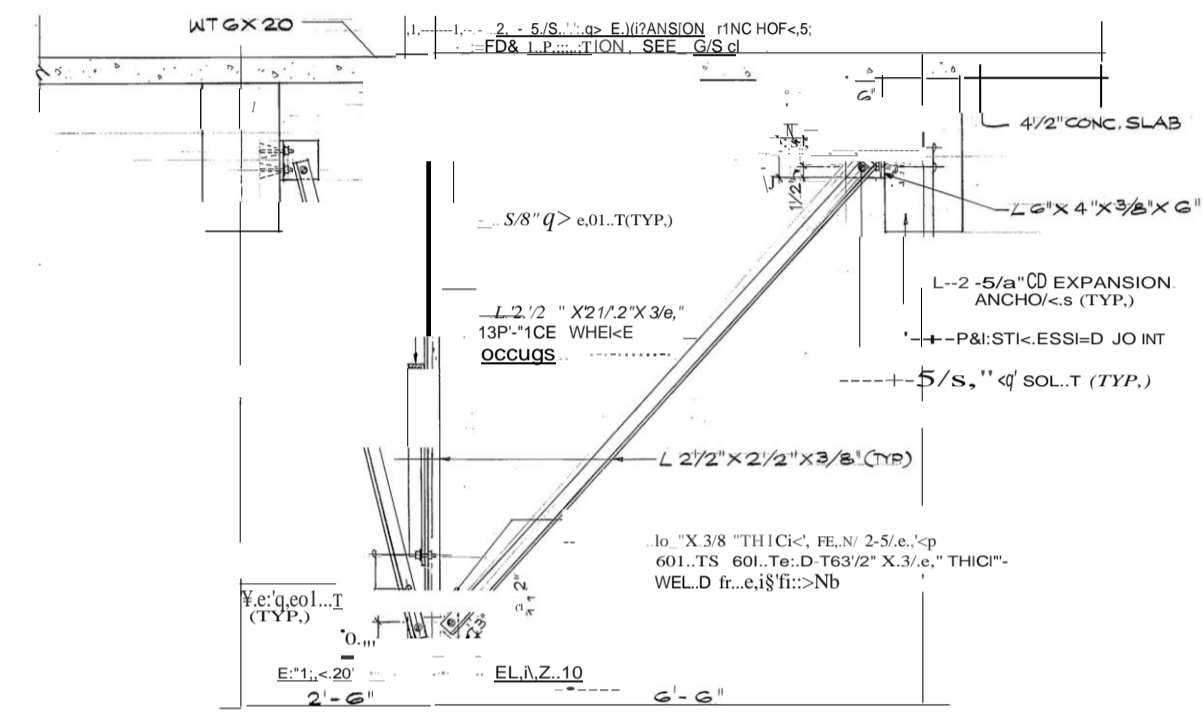

**SECTION - TYPICAL TRANSVERSE BRACE**

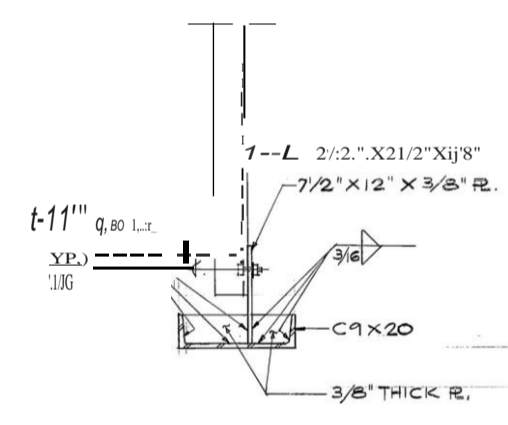

**SECTION 4-1**

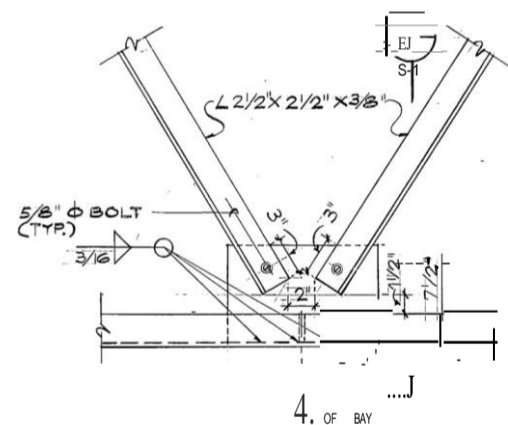

**DETAIL F**

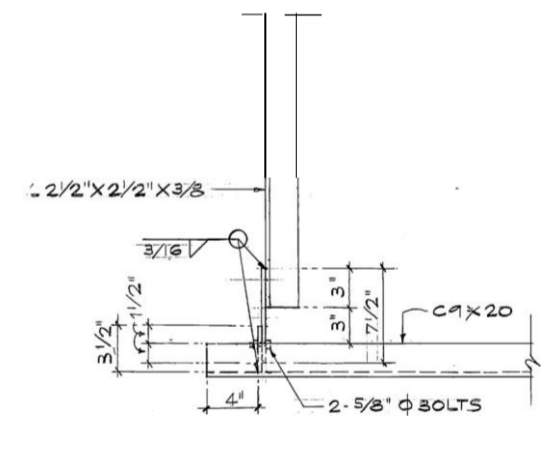

**DETAIL E**

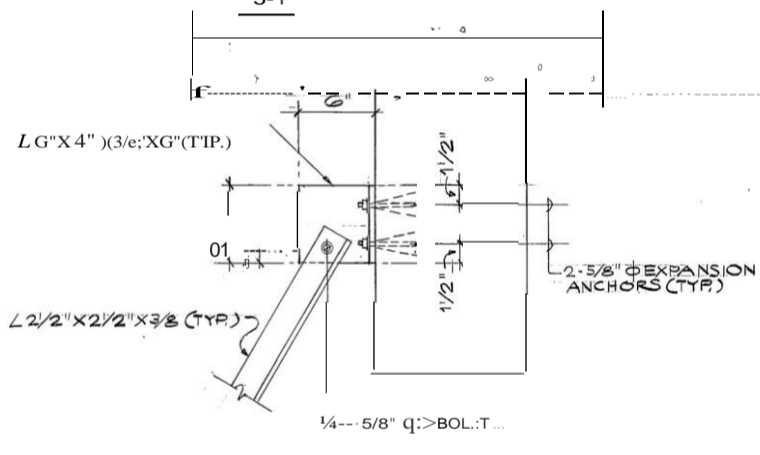

**DETAIL D**

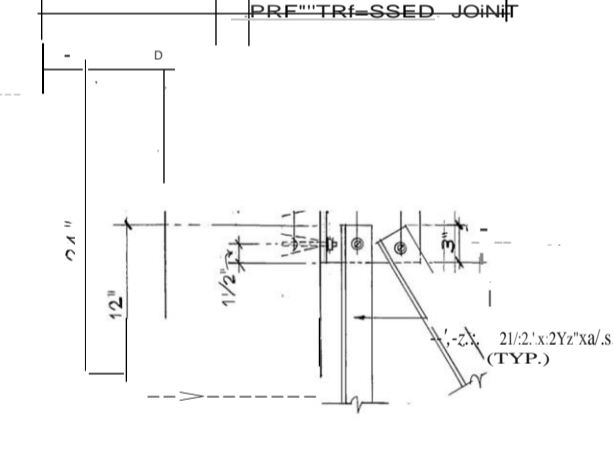

**DETAIL C**

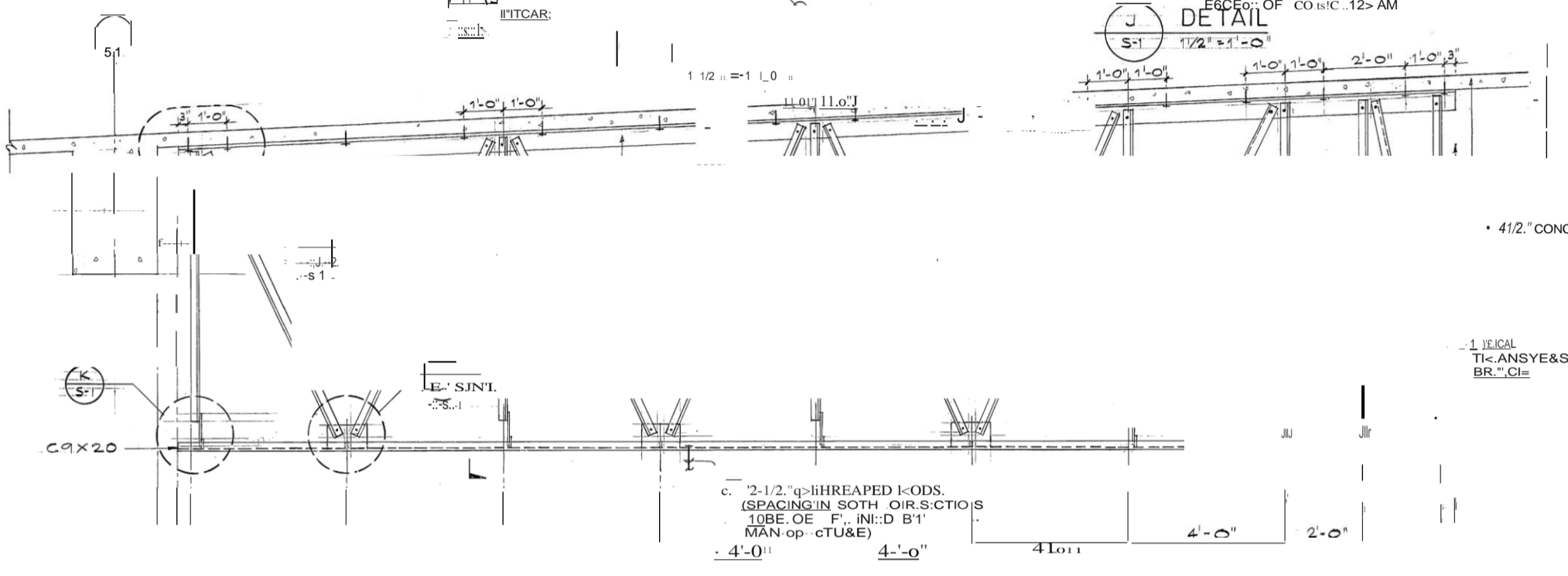

**ELEVATION 5-1**

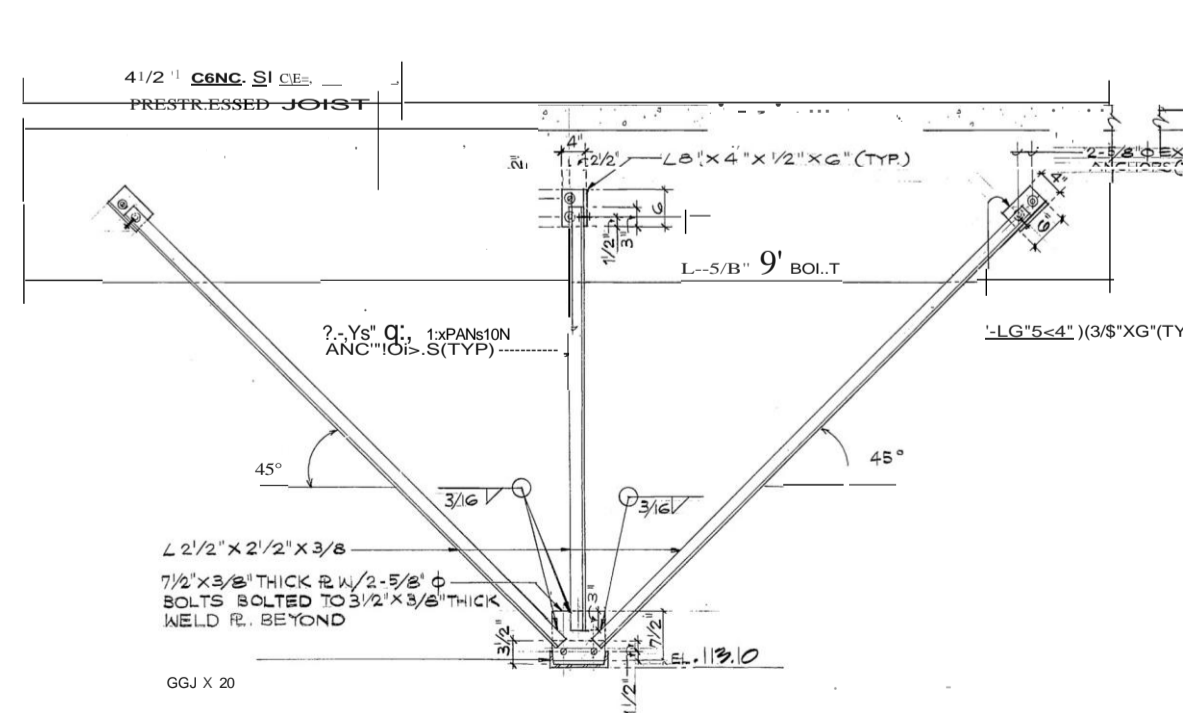

**SECTION AT PRE-STRESSED JOIST**

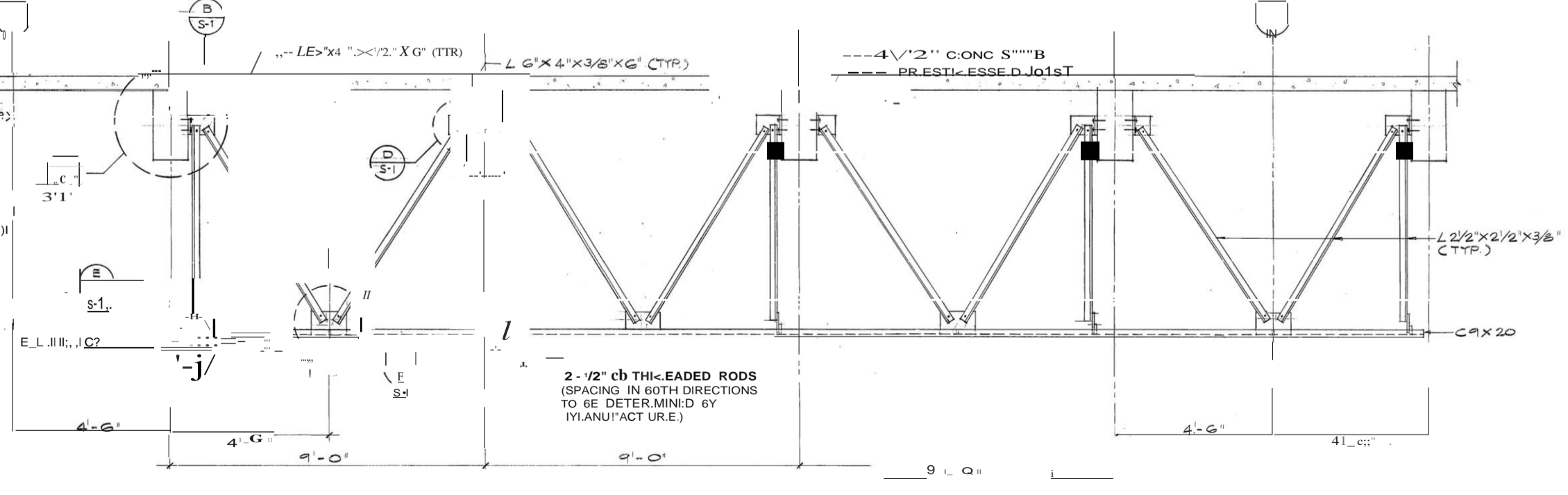

**ELEVATION**

NOTE: FOR OTHER INFO, NOTED

NOTE: 5/8\"/>

## **Requirements of Chapter 104, HRS Wages and Hours of Employees on Public Works Law**

---

Chapter 104, HRS, applies to every public works construction project over \$2,000, regardless of the method of procurement or financing (purchase order, voucher, bid, contract, lease arrangement, warranty, SPRB).

### **Rate of Wages for Laborers and Mechanics**

- Minimum prevailing wages (basic hourly rate plus fringe benefits), as determined by the Director of Labor and Industrial Relations and published in wage rate schedules, shall be paid to the various classes of laborers and mechanics working on the job site. [§104-2(a), (b), Hawaii Revised Statutes (HRS)]
- If the Director of Labor determines that prevailing wages have increased during the performance of a public works contract, the rate of pay of laborers and mechanics shall be raised accordingly. [§104-2(a) and (b), HRS; §12-22-3(d) Hawaii Administrative Rules (HAR)]

### **Overtime**

- Laborers and mechanics working on a Saturday, Sunday, or a legal holiday of the State or more than eight hours a day on any other day shall be paid overtime compensation at not less than one and one-half times the basic hourly rate plus the cost of fringe benefits for all hours worked. If the Director of Labor determines that a prevailing wage is defined by a collective bargaining agreement, the overtime compensation shall be at the rates set by the applicable collective bargaining agreement [§§104-1, 104-2(c), HRS; §12-22-4.1, HAR]

### **Weekly Pay**

- Laborers and mechanics employed on the job site shall be paid their full wages at least once a week, without deduction or rebate, except for legal deductions, within five working days after the cutoff date. [§104-2(d), HRS]

### **Posting of Wage Rate Schedules**

- Wage rate schedules with the notes for prevailing wages and special overtime rates, shall be posted by the contractor in a prominent and easily accessible place at the job site. A copy of the entire wage rate schedule shall be given to each laborer and mechanic employed under the contract, except when the employee is covered by a collective bargaining agreement. [§104-2(d), HRS]

### **Withholding of Accrued Payments**

- If necessary, the contracting agency may withhold accrued payments to the contractor to pay to laborers and mechanics employed by the contractor or subcontractor on the job site any difference between the wages required by the public works contract or specifications and the wages received. [§104-2(e), HRS]

### **Certified Weekly Payrolls and Payroll Records**

- A certified copy of all payrolls shall be submitted weekly to the contracting agency. [§104-3(a), HRS; §12-22-10, HAR]
- The contractor is responsible for the submission of certified copies of the payrolls of all subcontractors. The certification shall affirm that the payrolls are correct and complete, that the wage rates listed are not less than the applicable rates contained in the applicable wage rate schedule, and that the classifications for each laborer or mechanic conform with the work the laborer or mechanic performed. [§104-3(a), HRS; §12-22-10, HAR]
- Payroll records shall be maintained by the contractor and subcontractors for three years after completion of construction. The records shall contain: [§104-3(b), HRS; §12-22-10, HAR]
  - the name and home address of each employee
  - the last four digits of social security number
  - a copy of the apprentice's registration with DLIR
  - the employee's correct classification
  - rate of pay (basic hourly rate + fringe benefits)
  - itemized list of fringe benefits paid
  - daily and weekly hours worked
  - weekly straight time and overtime earnings
  - amount and type of deductions
  - total net wages paid
  - date of payment
- Records shall be made available for examination by the contracting agency, the Department of Labor and Industrial Relations (DLIR), or any of its authorized representatives, who may also interview employees during working hours on the job. [§§104-3(c), 104-22(a), HRS; §12-22-10, HAR]

## Termination of Work on Failure to Pay Wages

- If the contracting agency finds that any laborer or mechanic employed on the job site by the contractor or any subcontractor has not been paid prevailing wages or overtime, the contracting agency may, by written notice to the contractor, terminate the contractor's or subcontractor's right to proceed with the work or with the part of the work in which the required wages or overtime compensation have not been paid. The contracting agency may complete this work by contract or otherwise, and the contractor or contractor's sureties shall be liable to the contracting agency for any excess costs incurred. [§104-4, HRS]

## Apprentices

- Apprentice wage rates apply to contractors who are a party to a bona fide apprenticeship program which has been registered with the DLIR. In order to be paid apprentice rates, apprentices must be parties to an agreement either registered with or recognized as a USDOL nationally approved apprenticeship program by the DLIR, Workforce Development Division, (808) 586-8877, and the apprentice must be individually registered by name with the DLIR. [§12-22-6(1) and (2), HAR]
- The number of apprentices on any public work in relation to the number of journeyworkers in the same craft classification as the apprentices employed by the same employer on the same public work may not exceed the ratio allowed under the apprenticeship standards registered with or recognized by the DLIR. A registered or recognized apprentice receiving the journeyworker rate will not be considered a journeyworker for the purpose of meeting the ratio requirement. [§12-22-6(3), HAR]

## Enforcement

- To ensure compliance with the law, DLIR and the contracting agency will conduct investigations of contractors and subcontractors. If a contractor or subcontractor violates the law, the penalties are: [§104-24, HRS]
  - First Violation Equal to 25% of back wages found due or \$250 per offense up to \$2,500, whichever is greater.
  - Second Violation Equal to amount of back wages found due or \$500 for each offense up to \$5,000, whichever is greater.
  - Third Violation Equal to two times the amount of back wages found due or \$1,000 for each offense up to \$10,000, whichever is greater; and  
**Suspension** from doing any new work on any public work of a governmental contracting agency for three years.
- A violation would be deemed a second violation if it occurs within two years of the **first notification of violation**, and a third violation if it occurs within three years of **the second notification of violation**. [§104-24, HRS; §12-22-25(b), HAR]
- **Suspension:** For a first or second violation, the department shall immediately suspend a contractor who fails to pay wages or penalties until all wages and penalties are paid in full. For a third violation, the department shall penalize and suspend the contractor as described above, **except that if the contractor continues to violate the law, then the department shall immediately suspend the contractor for a mandatory three years. The contractor shall remain suspended until all wages and penalties are paid in full.** [§§104-24, 104-25, HRS]
- **Suspension:** Any contractor who fails to make payroll records accessible or provide requested information within 10 days, or fails to keep or falsifies any required record, shall be assessed a penalty including suspension as provided in Section 104-22(b) and 104-25(a)(3), HRS. [§104-3(c), HRS; §12-22-26, HAR]
- If any contractor interferes with or delays any investigation, the contracting agency shall withhold further payments until the delay has ceased. Interference or delay includes failure to provide requested records or information within ten days, failure to allow employees to be interviewed during working hours on the job, and falsification of payroll records. The department shall assess a penalty of \$10,000 per project, and \$1,000 per day thereafter, for interference or delay. [§104-22(b), HRS; §12-22-26, HAR]
- Failure by the contracting agency to include in the provisions of the contract or specifications the requirements of Chapter 104, HRS, relating to coverage and the payment of prevailing wages and overtime, is not a defense of the contractor or subcontractor for noncompliance with the requirements of this chapter. [§104-2(f), HRS]

For additional information, visit the department's website at <http://labor.hawaii.gov/wsd> or contact any of the following DLIR offices:



Oahu (Wage Standards Division)..... (808) 586-8777  
Hawaii Island ..... (808) 974-6464  
Maui and Kauai ..... (808) 243-5322

STATE OF HAWAII  
DEPARTMENT OF TRANSPORTATION  
AIRPORTS

PROPOSAL

PROPOSAL TO THE STATE OF HAWAII  
DEPARTMENT OF TRANSPORTATION  
AIRPORTS

PROJECT: REPLACE IIT CONFERENCE  
CENTER ROOM DIVIDERS  
DANIEL K. INOUE INTERNATIONAL AIRPORT  
HONOLULU, OAHU, HAWII

PROJECT NO.: CO1342-43

CONTRACT TIME: All work under this Contract shall be completed within  
THREE HUNDRED SIXTY-FIVE (365) CALENDAR  
DAYS from the date indicated in the Notice to Proceed  
from the State.

LIQUIDATED DAMAGES: FOUR HUNDRED FIFTY DOLLARS (\$450.00) for each  
and every calendar day for failure to complete the project in  
the time stated above.

ELECTRONIC SUBMITTAL: The bidder shall submit the proposal in HiePRO. The proposal  
shall be UPLOADED to HiePRO prior to the bid opening date and  
time. See SPECIAL PROVISIONS – 2.8 PREPARATION AND  
DELIVERY OF BID – for additional information.

PROJECT MANAGER: Benton Ho, Airport Facilities Engineer  
Department of Transportation, Airports  
400 Rodgers Blvd., Suite 700  
Honolulu, Hawaii 96819  
808) 838-8804

Project No. CO1342-43

Director of Transportation  
869 Punchbowl Street  
Honolulu, Hawaii 96813

Dear Sir:

The undersigned Bidder declares the following:

1. It has not, either directly or indirectly, entered into any agreement, participated in any collusion, or otherwise taken any action in restraint of free competitive bidding in connection with this proposal.
2. It has not been assisted or represented on this matter by any individual who has, in a State capacity, been involved in the subject matter of this contract within the past two years.
3. It has not and will not, either directly or indirectly offered or given a gratuity (i.e. an entertainment or gift) to any State or County employee to obtain a contract or favorable treatment under a contract.

The undersigned Bidder further agrees to the following:

1. If this proposal is accepted, it shall execute a contract with the Department to provide all necessary labor, machinery, tools, equipment, apparatus and any other means of construction, to do all the work and to furnish all the materials specified in the contract in the manner and within the time therein prescribed in the contract, and that it shall accept in full payment therefore the sum of the unit and/or lump sum prices as set forth in the attached proposal schedule for the actual quantities of work performed and materials furnished and furnish satisfactory security in accordance with Section 103D-324, Hawaii Revised Statutes, within 10 days after the award of the contract or within such time as the Director of Transportation may allow after the undersigned has received the contract documents for execution, and is fully aware that non-compliance with the aforementioned terms will result in the forfeiture of the full amount of the bid guarantee required under Section 103D-323, Hawaii Revised Statutes.
2. That the quantities given in the attached proposal schedule are approximate only and are intended principally to serve as a guide in determining and comparing the bids.
3. That the Department does not either expressly or by implication, agree that the actual amount of work will correspond therewith, but reserves the right to increase or decrease the amount of any class or portion of the work, or to omit portions of the work, as may be deemed necessary or advisable by the Director of Transportation, and that all increased or decreased quantities of work shall be performed at the unit prices set forth in the attached proposal schedule except as provided for in the specifications.

4. In case of a discrepancy between unit prices and the totals in said Proposal Schedule, the unit prices shall prevail.
5. Agrees to begin work within 10 working days after the date of notification to commence with the work, which date is in the notice to proceed, and shall finish the entire project within the time prescribed.
6. The Director of Transportation reserves the right to reject any or all bids and to waive any defects when in the Director's opinion such rejections or waiver will be for the best interest of the public.

The Bidder acknowledges receipt of and certifies that it has completely examined the following listed items: the Hawaii Department of Transportation, Air and Water Transportation Facilities Division General Provisions for Construction Projects dated 2016, the Notice to Bidders, the Special Provisions, if any, the Technical Provisions, the Proposal, the Contract and Bond Forms, and the Project Plans.

In accordance with Section 103D-323, Hawaii Revised Statutes, this proposal is accompanied with a bid security in the amount of 5% of the total amount bid, in the form checked below. (Check applicable bid security submitted with bid.)

Surety Bid Bond (Use standard form),

Cash,

Cashier's Check,

Certified Check, or

\_\_\_\_\_  
(Fill in other acceptable security.)

The undersigned Bidder acknowledges receipt of any addendum issued by the Department by recording in the space below the date of receipt.

Addendum No. 1 \_\_\_\_\_

Addendum No. 3 \_\_\_\_\_

Addendum No. 2 \_\_\_\_\_

Addendum No. 4 \_\_\_\_\_

In accordance with Section 103D-302, Hawaii Revised Statutes, the undersigned as Bidder, has listed the name of each person or firm, who will be engaged by the Bidder on the project as a Subcontractor or Joint Contractor and the nature of work to be done by each. The Bidder must adequately and unambiguously disclose the unique nature and scope of the work to be performed by each Subcontractor or Joint Contractor. For each listed firm, the Bidder declares the respective firm is a Subcontractor or Joint Contractor and is subject to evaluation as a Subcontractor or Joint Contractor. It is understood that failure to comply with the aforementioned requirements may be cause for rejection of the bid submitted.

<u>Name of Subcontractor</u>	<u>Nature and Scope of Work</u>
1. _____	_____
2. _____	_____
3. _____	_____
4. _____	_____
5. _____	_____
6. _____	_____
7. _____	_____
8. _____	_____

<u>Name of Joint Contractor</u>	<u>Nature and Scope of Work</u>
1. _____	_____
2. _____	_____
3. _____	_____

("None" or if left blank indicates no Subcontractor or Joint Contractor; if more space is needed, attach additional sheets.)

The undersigned hereby certifies that the bid prices contained in the attached proposal schedule have been carefully checked and are submitted as correct and final.

This declaration is made with the understanding that the undersigned is subject to the penalty of perjury under the laws of the United States and is in violation of the Hawaii Penal Code, Section 710-1063, unsworn falsification to authorities, of the Hawaii Revised Statutes, for knowingly rendering a false declaration.

\_\_\_\_\_  
Bidder (Company Name)

By \_\_\_\_\_  
Authorized Signature

\_\_\_\_\_  
Print Name and Title

\_\_\_\_\_  
Business Address

\_\_\_\_\_  
Business Telephone                      Email

\_\_\_\_\_  
Date

\_\_\_\_\_  
Contact Person (If different from above)

Phone: \_\_\_\_\_ Email: \_\_\_\_\_

NOTE:

If Bidder is a CORPORATION, the legal name of the corporation shall be set forth above, the corporate seal affixed, together with the signature(s) of the officer(s) authorized to sign contracts for the corporation. Please attach to this page current (not more than six months old) evidence of the authority of the officer(s) to sign for the corporation.

If Bidder is a PARTNERSHIP, the true name of the partnership shall be set forth above, with the signature(s) of the general partner(s). Please attach to this page current (not more than six months old) evidence of the authority of the partner authorized to sign for the partnership.

If Bidder is an INDIVIDUAL, the bidder's signature shall be placed above.

If signature is by an agent, other than an officer of a corporation or a partner of a partnership, a POWER OF ATTORNEY must be on file with the Department before opening bids or submitted with the bid. Otherwise, the Department may reject the bid as irregular and unauthorized.

## **PREFERENCES**

Bidders agree that preferences shall be taken into consideration to determine the low bidder in accordance with said Sections and the rules promulgated, however, the award of contract will be in the amount of the bid offered exclusive of any preferences.

### **A. HAWAII PRODUCTS PREFERENCE**

In accordance with ACT 174, SLH 2022, effective June 27, 2022, Hawaii Products Preference shall not apply to solicitations for public works construction. Therefore, the Hawaii Products Preference shall not apply to this project.

### **B. APPRENTICESHIP PROGRAMS PREFERENCE**

In accordance with ACT 17, SLH 2009 – Apprenticeship Program, a 5% bid adjustment for bidders that are parties to apprenticeship agreements pursuant to Hawaii Revised Statutes (HRS) Section 103-55.6 may be applied to the bidder's price for evaluation purposes.

Any bidder seeking this preference must be a party to an apprenticeship agreement registered with the Department of Labor and Industrial Relations at the time the offer is made for each apprenticeable trade the bidder will employ to construct the public works projects for which the offer is being made.

The bidder is responsible for complying with all submission requirements for registration of its apprenticeship program before requesting the preference.

( ) **Yes, I wish to be considered for the Apprenticeship Programs Preference. I have included Certification Form(s) 1 with my bid.**

### **C. RECYCLED PRODUCT PREFERENCE**

Recycled product preference shall not apply to this proposal.

**PROPOSAL SCHEDULE**

**REPLACE IIT CONFERENCE CENTER ROOM DIVIDERS  
DANIEL K. INOUYE INTERNATIONAL AIRPORT  
HONOLULU, OAHU, HAWAII  
STATE PROJECT NO. CO1342-43**

Item No.	Description	Approx. Qty	Unit Price	Total
<b>A <u>DIVISION 1 - GENERAL REQUIREMENTS</u></b>				
01010.1	Unforeseen Conditions	Allowance	Allowance	\$ <u>50,000.00</u>
01524.1	Construction Waste Management	LS	LS	\$ _____
01561.1	Construction Site Runoff Control Program	LS	LS	\$ _____
01562.1	Management of Contaminated Medias	Allowance	Allowance	\$ <u>5,000.00</u>
01565.1	Security Measures	Allowance	Allowance	\$ <u>5,000.00</u>
01700.1	Mobilization (Not to exceed 6% of sum of all items, excluding this item, all allowances and force account items)	LS	LS	\$ _____
<b>D <u>DIVISION 10 - SPECIALTIES</u></b>				
10222	Operable Partitions	LS	LS	\$ _____

---

**TOTAL AMOUNT FOR COMPARISON OF BIDS** \$ \_\_\_\_\_

---

The prices bid herein shall include all labor, materials, equipment, and incidentals necessary to construct all items in place, including installation and testing of equipment, complete and ready for operation, all in accordance with the plans and specifications.

Notes:

1. Bids shall include all Federal, State, County and other applicable taxes.
2. The TOTAL AMOUNT FOR COMPARISON OF BIDS will be used to determine the lowest responsible bidder.
3. Bidders must complete all unit prices and amounts. Failure to do so may be grounds for rejection of bid.
4. The State reserves the right to reject any or all Proposals and to waive any defects in the best interest of the State.
5. The bidder's attention is directed to Section 2.11 – BID SECURITY and Section 2.24 – REQUIREMENTS OF CONTRACT BONDS of the “General Provisions” as amended by the Special Provisions.

## PROPOSAL SCHEDULE

**REPLACE IIT CONFERENCE CENTER ROOM DIVIDERS  
DANIEL K. INOUE INTERNATIONAL AIRPORT  
HONOLULU, OAHU, HAWAII  
STATE PROJECT NO. CO1342-43**

6. If the lowest TOTAL AMOUNT FOR COMPARISON OF BIDS is less than, or approximately equal to the funds available for this project, an award will be made to the lowest responsible bidder.
7. If the lowest TOTAL AMOUNT FOR COMPARISON OF BIDS exceeds the funds available, the State reserves the right to negotiate with the lowest responsible bidder as permitted under Section 103D-302, Hawaii Revised Statutes, to further reduce the scope of work and award a contract thereafter.
8. The bidder shall submit the proposal in HiePRO. The proposal shall be UPLOADED to HiePRO prior to the bid opening date and time. Proposals received after said due date and time shall not be considered. Original (wet ink) proposal documents are not required to be submitted. The award will be made based on proposals uploaded in HiePRO. Any and all other additional documents explicitly designated and labeled as CONFIDENTIAL OR PROPRIETARY shall be UPLOADED SEPARATELY to HiePRO. If there is a conflict between this specification and its HiePRO solicitation, the specifications shall govern and control unless otherwise specified.

# SURETY BID BOND

Bond No. \_\_\_\_\_

KNOW TO ALL BY THESE PRESENTS:

That we, \_\_\_\_\_  
(full name or legal title of offeror)

as Offeror, hereinafter called the Principal, and

\_\_\_\_\_  
(name of bonding company)

as Surety, hereinafter called Surety, a corporation authorized to transact business as a Surety in the State of Hawaii, are held and firmly bound unto

\_\_\_\_\_  
(State/county entity)

as Owner, hereinafter called Owner, in the penal sum of

\_\_\_\_\_  
(required amount of bid security)

Dollars(\$ \_\_\_\_\_), lawful money of the United States of America, for the payment of which sum well and truly to be made, the said Principal and the said Surety bind ourselves, our heirs, executors, administrators, successors and assigns, jointly and severally, firmly by these presents.

## WHEREAS:

The Principal has submitted an offer for

\_\_\_\_\_  
(project by number and brief description)

## NOW, THEREFORE:

The condition of this obligation is such that if the Owner shall reject said offer, or in the alternate, accept the offer of the Principal and the Principal shall enter into a contract with the Owner in accordance with the terms of such offer, and give such bond or bonds as may be specified in the solicitation or Contract Documents with good and sufficient surety for the faithful performance of such Contract and for the prompt payment of labor and material furnished in the prosecution thereof as specified in the solicitation then this obligation shall be null and void, otherwise to remain in full force and effect.

Signed this \_\_\_\_\_ day of \_\_\_\_\_

\_\_\_\_\_  
Name of Principal (Offeror) (Seal)

\_\_\_\_\_  
Signature

\_\_\_\_\_  
Title

\_\_\_\_\_  
Name of Surety (Seal)

\_\_\_\_\_  
Signature

\_\_\_\_\_  
Title

STATE OF HAWAII  
DEPARTMENT OF TRANSPORTATION  
AIRPORTS

FORMS

**PERFORMANCE BOND (SURETY)**  
(6/21/07)

**KNOW TO ALL BY THESE PRESENTS:**

That \_\_\_\_\_,  
*(Full Legal Name and Street Address of Contractor)*

as Contractor, hereinafter called Principal, and \_\_\_\_\_  
\_\_\_\_\_  
*(Name and Street Address of Bonding Company)*

as Surety, hereinafter called Surety, a corporation(s) authorized to transact business as a  
surety in the State of Hawaii, are held and firmly bound unto the \_\_\_\_\_,  
*(State/County Entity)*

its successors and assigns, hereinafter called Obligee, in the amount of \_\_\_\_\_

\_\_\_\_\_ DOLLARS (\$ \_\_\_\_\_), to which payment Principal and Surety bind themselves,  
their heirs, executors, administrators, successors and assigns, jointly and severally, firmly by  
these presents.

**WHEREAS**, the above-bound Principal has signed a Contract with Obligee on  
\_\_\_\_\_, for the following project: \_\_\_\_\_  
\_\_\_\_\_  
\_\_\_\_\_  
\_\_\_\_\_

hereinafter called Contract, which Contract is incorporated herein by reference and made a part  
hereof.

**NOW THEREFORE**, the condition of this obligation is such that:

If the Principal shall promptly and faithfully perform, and fully complete the Contract in  
strict accordance with the terms of the Contract as said Contract may be modified or amended  
from time to time; then this obligation shall be void; otherwise to remain in full force and effect.

Surety to this Bond hereby stipulates and agrees that no changes, extensions of time, alterations, or additions to the terms of the Contract, including the work to be performed thereunder, and the specifications or drawings accompanying same, shall in any way affect its obligation on this bond, and it does hereby waive notice of any such changes, extensions of time, alterations, or additions, and agrees that they shall become part of the Contract.

In the event of Default by the Principal, of the obligations under the Contract, then after written Notice of Default from the Oblige to the Surety and the Principal and subject to the limitation of the penal sum of this bond, Surety shall remedy the Default, or take over the work to be performed under the Contract and complete such work, or pay moneys to the Oblige in satisfaction of the surety's performance obligation on this bond.

Signed this \_\_\_\_\_ day of \_\_\_\_\_, \_\_\_\_\_.

(Seal)

\_\_\_\_\_  
Name of Principal (Contractor)

\*

\_\_\_\_\_  
Signature

\_\_\_\_\_  
Title

(Seal)

\_\_\_\_\_  
Name of Surety

\*

\_\_\_\_\_  
Signature

\_\_\_\_\_  
Title

**\*ALL SIGNATURES MUST BE ACKNOWLEDGED  
BY A NOTARY PUBLIC**

# PERFORMANCE BOND

KNOW TO ALL BY THESE PRESENTS:

That we, \_\_\_\_\_, \_\_\_\_\_, \_\_\_\_\_  
/fu// legal name and street address of Contractor)

as Contractor, hereinafter called Contractor, is held and firmly bound unto the

\_\_\_\_\_  
(State/County entity)

its successors and assigns, as Obligee, hereinafter called Obligee, in the amount

\_\_\_\_\_ DOLLARS \$ \_\_\_\_\_  
(Dollar amount of Contract)

lawful money of the United States of America, for the payment of which to the said Obligee, well and truly to be made, Contractor binds itself, its heir, executors, administrators, successors and assigns, firmly by these presents. Said amount is evidenced by:

**D Legal Tender;**

**D Share Certificate unconditionally assigned to or made payable at sight to**  
Description: \_\_\_\_\_,

**D Certificate of Deposit**, No. \_\_\_\_\_, dated \_\_\_\_\_ issued  
by \_\_\_\_\_ drawn on \_\_\_\_\_ a bank, savings  
institution or credit union insured by the Federal Deposit Insurance Corporation or the  
National Credit Union Administration, payable at sight or unconditionally assigned to \_\_\_\_\_

**D Cashier's Check** No. \_\_\_\_\_, dated \_\_\_\_\_  
drawn on \_\_\_\_\_ a  
bank, savings institution or credit union insured by the Federal Deposit Insurance  
Corporation or the National Credit Union Administration, payable at sight or  
unconditionally assigned to \_\_\_\_\_

**D Teller's Check** No. \_\_\_\_\_, dated \_\_\_\_\_  
drawn on \_\_\_\_\_ a  
bank, savings institution or credit union insured by the Federal Deposit Insurance  
Corporation or the National Credit Union Administration, payable at sight or  
unconditionally assigned to \_\_\_\_\_

**D Treasurer's Check** No. \_\_\_\_\_, dated \_\_\_\_\_  
drawn on \_\_\_\_\_ a  
bank, savings institution or credit union insured by the Federal Deposit Insurance  
Corporation or the National Credit Union Administration, payable at sight or  
unconditionally assigned to \_\_\_\_\_

**Official Check** No. \_\_\_\_\_, dated \_\_\_\_\_  
drawn on \_\_\_\_\_ a  
bank, savings institution or credit union insured by the Federal Deposit Insurance  
Corporation or the National Credit Union Administration, payable at sight or  
unconditionally assigned to \_\_\_\_\_

**Certified Check** No. \_\_\_\_\_, dated \_\_\_\_\_  
accepted by a bank, savings institution or credit union insured by the Federal Deposit  
Insurance Corporation or the National Credit Union Administration, payable at sight or  
unconditionally assigned to \_\_\_\_\_

**WHEREAS:**

The Contractor has by written agreement dated \_\_\_\_\_ entered into a contract with Obligee for the following Project: \_\_\_\_\_

hereinafter called Contract, which Contract is incorporated herein by reference and made a part hereof.

**NOW THEREFORE,**

The Condition of this obligation is such that, if Contractor shall promptly and faithfully perform the Contract in accordance with, in all respects, the stipulations, agreements, covenants and conditions of the Contract as it now exists or may be modified according to its terms, and shall deliver the Project to the Obligee, or to its successors or assigns, fully completed as in the Contract specified and free from all liens and claims and without further cost, expense or charge to the Obligee, its officers, agents, successors or assigns, free and harmless from all suits or actions of every nature and kind which may be brought for or on account of any injury or damage, direct or indirect, arising or growing out of the doing of said work or the repair or maintenance thereof or the manner of doing the same or the neglect of the Contractor or its agents or servants or the improper performance of the Contract by the Contractor or its agents or servants or from any other cause, then this obligation shall be void; otherwise it shall be and remain in full force and effect.

**AND IT IS HEREBY STIPULATED AND AGREED** that suit on this bond may be brought before a court of competent jurisdiction without a jury, and that the sum or sums specified in the said Contract as liquidated damages, if any, shall be forfeited to the Obligee, its successors or assigns, in the event of a breach of any, or all, or any part of, covenants, agreements, conditions, or stipulations contained in the Contract or in this bond in accordance with the terms thereof.

The amount of this bond may be reduced by and to the extent of any payment or payments made in good faith hereunder.

Signed and sealed this \_\_\_\_\_ **day** \_\_\_\_\_, \_\_\_\_\_ -

(Seal) \_\_\_\_\_  
Name of Contractor

\_\_\_\_\_  
Signature\*

\_\_\_\_\_  
Title

\* ALL SIGNATURES MUST BE ACKNOWLEDGED  
BY A NOTARY PUBLIC

**LABOR AND MATERIAL PAYMENT BOND (SURETY)**  
(6/21/07)

**KNOW TO ALL BY THESE PRESENTS:**

That \_\_\_\_\_,  
*(Full Legal Name and Street Address of Contractor)*

as Contractor, hereinafter called Principal, and \_\_\_\_\_  
\_\_\_\_\_  
*(Name and Street Address of Bonding Company)*

as Surety, hereinafter called Surety, a corporation(s) authorized to transact business as a surety in the State of Hawaii, are held and firmly bound unto the \_\_\_\_\_,  
*(State/County Entity)*

its successors and assigns, hereinafter called Obligee, in the amount of \_\_\_\_\_

\_\_\_\_\_ Dollars (\$\_\_\_\_\_), to which payment Principal and Surety bind themselves, their heirs, executors, administrators, successors and assigns, jointly and severally, firmly by these presents.

**WHEREAS**, the above-bound Principal has signed Contract with the Obligee on \_\_\_\_\_ for the following project: \_\_\_\_\_  
\_\_\_\_\_  
\_\_\_\_\_  
\_\_\_\_\_

hereinafter called Contract, which Contract is incorporated herein by reference and made a part hereof.

**NOW THEREFORE**, the condition of this obligation is such that if the Principal shall promptly make payment to any Claimant, as hereinafter defined, for all labor and materials supplied to the Principal for use in the performance of the Contract, then this obligation shall be void; otherwise to remain in full force and effect.

1. Surety to this Bond hereby stipulates and agrees that no changes, extensions of time, alterations, or additions to the terms of the Contract, including the work to be performed thereunder, and the specifications or drawings accompanying same, shall in any way affect its obligation on this bond, and it does hereby waive notice of any such changes, extensions of time, alterations, or additions, and agrees that they shall become part of the Contract.

2. A "Claimant" shall be defined herein as any person who has furnished labor or materials to the Principal for the work provided in the Contract.

Every Claimant who has not been paid amounts due for labor and materials furnished for work provided in the Contract may institute an action against the Principal and its Surety on this bond at the time and in the manner prescribed in Section 103D-324, Hawaii Revised Statutes, and have the rights and claims adjudicated in the action, and judgment rendered thereon; subject to the Obligee's priority on this bond. If the full amount of the liability of the Surety on this bond is insufficient to pay the full amount of the claims, then after paying the full amount due the Obligee, the remainder shall be distributed pro rata among the claimants.

Signed this \_\_\_\_\_ day of \_\_\_\_\_, \_\_\_\_\_.

(Seal)

\_\_\_\_\_  
Name of Principal (Contractor)

\*

\_\_\_\_\_  
Signature

\_\_\_\_\_  
Title

(Seal)

\_\_\_\_\_  
Name of Surety

\*

\_\_\_\_\_  
Signature

\_\_\_\_\_  
Title

**\*ALL SIGNATURES MUST BE ACKNOWLEDGED  
BY A NOTARY PUBLIC**

# LABOR AND MATERIAL PAYMENT BOND

KNOW TO ALL BY THESE PRESENTS:

That we, \_\_\_\_\_  
(full legal name and street address of Contractor)

as Contractor, hereinafter called Contractor, is held and firmly bound unto \_\_\_\_\_  
(State/County entity)

its successors and assigns, as Obligee, hereinafter called Obligee, in the amount

\_\_\_\_\_ DOLLARS (\$ \_\_\_\_\_)  
(Dollar amount of Contract)

lawful money of the United States of America, for the payment of which to the said Obligee, well and truly to be made, Contractor binds itself, its heir, executors, administrators, successors and assigns, firmly by these presents. Said amount is evidenced by:

**D Legal Tender;**

**D Share Certificate** unconditionally assigned to or made payable at sight to \_\_\_\_\_  
Description: \_\_\_\_\_

**D Certificate of Deposit**, No. \_\_\_\_\_, dated \_\_\_\_\_ issued by \_\_\_\_\_ drawn on \_\_\_\_\_ a bank, savings institution or credit union insured by the Federal Deposit Insurance Corporation or the National Credit Union Administration, payable at sight or unconditionally assigned to \_\_\_\_\_

**D Cashier's Check** No. \_\_\_\_\_, dated \_\_\_\_\_ drawn on \_\_\_\_\_ a bank, savings institution or credit union insured by the Federal Deposit Insurance Corporation or the National Credit Union Administration, payable at sight or unconditionally assigned to \_\_\_\_\_

**D Teller's Check** No. \_\_\_\_\_, dated \_\_\_\_\_ drawn on \_\_\_\_\_ a bank, savings institution or credit union insured by the Federal Deposit Insurance Corporation or the National Credit Union Administration, payable at sight or unconditionally assigned to \_\_\_\_\_

**D Treasurer's Check** No. \_\_\_\_\_, dated \_\_\_\_\_ drawn on \_\_\_\_\_ a bank, savings institution or credit union insured by the Federal Deposit Insurance Corporation or the National Credit Union Administration, payable at sight or unconditionally assigned to \_\_\_\_\_

**D Official Check** No. \_\_\_\_\_, dated \_\_\_\_\_ drawn on \_\_\_\_\_ a bank, savings institution or credit union insured by the Federal Deposit Insurance Corporation or the National Credit Union Administration, payable at sight or unconditionally assigned to \_\_\_\_\_

**D Certified Check** No. \_\_\_\_\_, dated \_\_\_\_\_ accepted by a bank, savings institution or credit union insured by the Federal Deposit Insurance Corporation or the National Credit Union Administration, payable at sight or unconditionally assigned to \_\_\_\_\_;

**WHEREAS:**

The Contractor has by written agreement dated \_\_\_\_\_ entered into a contract with Obligee for the following Project: \_\_\_\_\_

hereinafter called Contract, which Contract is incorporated herein by reference and made a part hereof.

**NOW THEREFORE,**

The condition of this obligation is such that, if Contractor shall promptly and faithfully perform the Contract in accordance with, in all respects, the stipulations, agreements, covenants and conditions of the Contract as it now exists or may be modified according to its terms, free from all liens and claims and without further cost, expense or charge to the Obligee, its officers, agents, successors or assigns, free and harmless from all suits or actions of every nature and kind which may be brought for or on account of any injury or damage, direct or indirect, arising or growing out of the doing of said work or the repair or maintenance thereof or the manner of doing the same or the neglect of the Contractor or its agents or servants or the improper performance of the Contract by the Contractor or its agents or servants or from any other cause, then this obligation shall be void; otherwise it shall be and remain in full force and effect.

**AND IT IS HEREBY STIPULATED AND AGREED** that suit on this bond may be brought before a court of competent jurisdiction without a jury, and that the sum or sums specified in the said Contract as liquidated damages, if any, shall be forfeited to the Obligee, its successors or assigns, in the event of a breach of any, or all, or any part of, covenants, agreements, conditions, or stipulations contained in the Contract or in this bond in accordance with the terms thereof.

**AND IT IS HEREBY STIPULATED AND AGREED** that this bond shall inure to the benefit of any and all persons entitled to file claims for labor performed or materials furnished in said work so as to give any and all such persons a right of action as contemplated by Sections 103D-324(d) and 103D-324(e), Hawaii Revised Statutes.

The amount of this bond may be reduced by and to the extent of any payment or payments made in good faith hereunder, inclusive of the payments of mechanics' liens which may be filed of record against the Project, whether or not claim for the amount of such lien be presented under and against this bond..

Signed this \_\_\_\_\_ day of \_\_\_\_\_

(Seal) \_\_\_\_\_

Name of Contractor

\_\_\_\_\_  
Signature\*

\_\_\_\_\_  
Title

ALL SIGNATURES MUST BE ACKNOWLEDGED BY A NOTARY PUBLIC

CHAPTER 104, HRS COMPLIANCE CERTIFICATE

The undersigned bidder does hereby certify to the following:

1. Individuals engaged in the performance of the contract on the job site shall be paid:

A. Not less than the wages that the director of labor and industrial relations shall have determined to be prevailing for corresponding classes of laborers and mechanics employed on public works projects; and

B. Overtime compensation at one and one-half times the basic hourly rate plus fringe benefits for hours worked on Saturday, Sunday, or a legal holiday of the State or in excess of eight hours on any other day.

2. All applicable laws of the federal and state governments relating to workers' compensation, unemployment compensation, payment of wages, and safety shall be fully complied with.

DATED at Honolulu, Hawaii, this \_\_\_\_\_ day of \_\_\_\_\_, 20\_\_\_\_.

\_\_\_\_\_  
«CONTRACTOR»  
Name of Corporation, Partnership, or Individual  
  
\_\_\_\_\_  
Signature and Title of Signer

Notary Seal  
NOTARY ACKNOWLEDGEMENT

Subscribed and sworn before me this \_\_\_\_\_ day of \_\_\_\_\_  
Notary signature \_\_\_\_\_  
Notary public, State of \_\_\_\_\_  
My Commission Expires: \_\_\_\_\_

Notary Seal  
NOTARY CERTIFICATION

Doc. Date: \_\_\_\_\_ #Pages: \_  
Notary Name: \_\_\_\_\_ Circuit  
Doc. Description: \_\_\_\_\_  
\_\_\_\_\_  
Notary signature \_\_\_\_\_  
Date \_\_\_\_\_

**CERTIFICATION OF COMPLIANCE  
FOR  
EMPLOYMENT OF STATE RESIDENTS  
HRS CHAPTER 103B, AS AMENDED BY ACT 192, SLH 2011**

Project Title: \_\_\_\_\_

Agency Project No: \_\_\_\_\_

Contract No.: \_\_\_\_\_

As required by Hawai'i Revised Statutes Chapter 103B, as amended by Act 192, Session Laws of Hawaii 2011-Employment of State Residents on Construction Procurement Contracts, I hereby certify under oath, that I am an officer of \_\_\_\_\_ and

(Name of Contractor or Subcontractor Company)

for the Project Contract indicated above, \_\_\_\_\_, \_\_\_\_\_, \_\_\_\_\_ was in

(Name of Contractor or Subcontractor Company)

compliance with HRS Chapter 103B, as amended by Act 192, SLH 2011, by employing a workforce of which not less than eighty percent are Hawai'i residents, as calculated according to the formula in the solicitation, to perform this Contract.

D I am an officer of the **Contractor** for this contract.

D I am an officer of a **Subcontractor** for this contract.

*CORPORATE SEAL*

\_\_\_\_\_  
(Name of Company)

\_\_\_\_\_  
(Signature)

\_\_\_\_\_  
(Print Name)

\_\_\_\_\_  
(Print Title)

Subscribed and sworn to me before this  
day of \_\_\_\_\_, 2011.

Doc. Date: ----- ~~#~~ of Pages \_\_\_ !" Circuit

Notary Name: \_\_\_\_\_

Doc. Description: \_\_\_\_\_

\_\_\_\_\_

\_\_\_\_\_

\_\_\_\_\_  
Notary Public, I" Circuit, State of Hawai'i  
My commission expires: \_\_\_\_\_

\_\_\_\_\_  
Notary Signature

\_\_\_\_\_  
Date

NOTARY CERTIFICATION

**EXHIBIT2**

**PROVISIONS TO BE INCLUDED IN  
CONSTRUCTION PROCUREMENT SOLICITATIONS**

1. Definitions for terms used in HRS Chapter 103B as amended by Act 192, SLH 2011:
  - a. "Contract" means contracts for construction under 103D, HRS.
  - b. "Contractor" has the same meaning as in Section 103D-104, HRS, provided that "contractor" includes a subcontractor where applicable.
  - c. "Construction" has the same meaning as in Section 103D-104, HRS.
  - d. "General Contractor" means any person having a construction contract with a governmental body.
  - e. "Procurement Officer" has the same meaning as in Section 103D-104, HRS.
  - f. "Resident" means a person who is physically present in the State of Hawai'i at the time the person claims to have established the person's domicile in the State of Hawai'i and shows the person's intent is to make Hawai'i the person's primary residence.
  - g. "Shortage trade" means a construction trade in which there is a shortage of Hawai'i residents qualified to work in the trade as determined by the Department of Labor and Industrial Relations.
  
2. HRS Chapter 103B as amended by Act 192, SLH 2011-Employment of State Residents Requirements:
  - a. A Contractor awarded a contract shall ensure that Hawai'i residents comprise not less than 80% of the workforce employed to perform the contract work on the project. The 80% requirement shall be determined by dividing the total number of hours worked on the contract by Hawai'i residents, by the total number of hours worked on the contract by all employees of the Contractor in the performance of the contract. The hours worked by any Subcontractor of the Contractor shall count towards the calculation for this section. The hours worked by employees within shortage trades, as determined by the Department of Labor and Industrial Relations (DUR), shall not be included in the calculation for this section.

- b. Prior to award of a contract, an Offeror/Bidder may withdraw an offer/bid without penalty if the Offeror/Bidder finds that it is unable to comply with HRS Chapter 103B as amended by Act 192, SLH 2011.
- c. Prior to starting any construction work, the Contractor shall submit the subcontract dollar amount for each of its Subcontractors.
- d. The requirements of this section shall apply to any subcontract of \$50,000 or more in connection with the Contractor; that is, such Subcontractors must also ensure that Hawai'i residents comprise not less than 80% of the Subcontractor's workforce used to perform the subcontract.
- e. The Contractor and any Subcontractor whose subcontract is \$50,000 or more shall comply with the requirements of HRS Chapter 103B as amended by Act 192, SLH 2011.
  - 1) Certification of compliance shall be made in writing under oath by an officer of the General Contractor and applicable Subcontractors and submitted with the final payment request.
  - 2) The certification of compliance shall be made under oath by an officer of the company by completing a "Certification of Compliance for Employment of State Residents" form and executing the Certificate before a licensed notary public.
  - 3) In addition to the certification of compliance as indicated above, the Contractor and Subcontractors shall maintain records such as certified payrolls for laborers and mechanics who performed work at the site and time sheets for all other employees who performed work on the project. These records shall include the names, addresses and number of hours worked on the project by all employees of the Contractor and Subcontractor who performed work on the project to validate compliance with HRS Chapter 103B as amended by Act 192, SLH 2011. The Contractor and Subcontractors shall retain these records and provide access to the State for a minimum period of four (4) years after the final payment, except that if any litigation, claim, negotiation, investigation, audit or other action involving the records has been started before the expiration of the four-year period, the Contractor and Subcontractors shall retain the records until completion of the action and resolution of all issues that arise from it, or until the end of the four-year period, whichever occurs later. Furthermore, it shall be the Contractor's responsibility to enforce compliance with this provision by any Subcontractor.

- f. A General Contractor or applicable Subcontractor who fails to comply with this section shall be subject to any of the following sanctions:
  - 1) With respect to the General Contractor, withholding of payment on the contract until the Contractor or its Subcontractor complies with HRS Chapter 103B as amended by Act 192, SLH 2011.
  - 2) Proceedings for debarment or suspension of the Contractor or Subcontractor under Hawai'i Revised Statutes §103D-702.
- 3. Conflict with Federal Law: This section shall not apply if the application of this section is in conflict with any federal law, or if the application of this section will disqualify the State from receiving Federal funds or aid.